

GOODWIN INTERNATIONAL LTD

Goodwin House
Leek Road
Stoke on Trent
England
ST1 3NR

Tel: +44 (0)1782 220000

Fax: +44 (0)1782 208060

E-mail: checkvalves@goodwingroup.com

INSTALLATION & MAINTENANCE INSTRUCTIONS FOR GOODWIN WAFER CHECK VALVES (ALL STYLES)

Applicable to valves supplied in conformance to
API 594 Standard

1. Nameplates & Marking

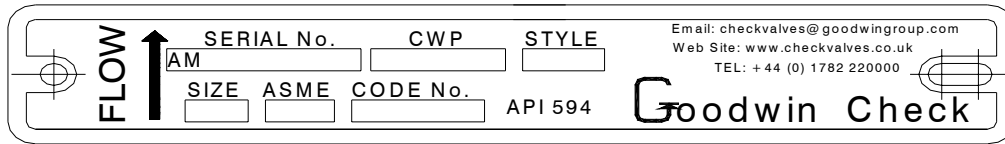

All Valves supplied in conformance to the API 594 Standard will be supplied with all the nameplates shown above attached.

2. Unpacking

- 2.0 Firstly, identify the valves required by checking identification tag and valve markings. Remove the required valves from the packing case, if necessary remove by mechanical means using the lifting points indicated on the valve.
- 2.1 If there are any special lifting requirements the instructions will be found attached to the inside face of the packing case lid.
- 2.2 Remove all flange face sealing materials (applied to prevent damage corrosion taking place during transit). Also remove flange opening covers, caps or disks from machined surfaces.

3. Prior To Installation

- 3.0. ALL machined surfaces must be cleaned using paraffin or similar liquid to remove all traces of protective coating, particularly on disk and body seat faces, also valve/gasket mating pipe flange seating faces.

4. Installation

- 4.0. When installing the valve into the required line, the valve identification tag (if required) is to be re-secured around a flange to flange clamping stud.
- 4.1. Check that the direction of flow arrow is correctly positioned.
- 4.2. If the valve is in a horizontal pipeline the disk hinge pin **MUST BE** in the vertical position for correct operation. If the valve is already assembled into the pipeline, the vertical hinge pin position can be determined by:-
 - 4.2.1. Valves **with external** hinge and stop pin retainers ('B' / 'BF' / 'BS' / 'BH' Style). These must be positioned vertically at the top and bottom of the valve body.
 - 4.2.2. Valves **without external** hinge and stop pin retailers ('BR' / 'BFR' / 'BSR' / 'BHR' / 'BWR' Style), i.e. retainer-less. The word '**TOP**' stamped on the body **MUST BE** positioned vertically at the top – 12 O'clock, or bottom – 6 O'clock position.
- 4.3. Ensure the direction of flow through the Pipeline matches the direction of flow indicated on the valve body.

4.4. Offer up the valve to the pipeline either by hand, or if necessary using a mechanical lifting device with the eyebolts fitted into the tapped holes, if provided in the body of the valve. Always use the eyebolts provided.

4.5. Before installing valve between mating pipe flanges, ensure all faces are clean, flat and free from all blurs and indents.

4.6. Fixing the valve between mating flanges:-

4.6.1 **For Valves secured by Bolting** – Assemble gaskets / ring joints of the type and material quoted in the specification on either side of valve face and between pipe flanges situated centrally between securing studs. Tighten studs to the required torque, using the opposite studs (180 degree tighten method) to ensure even loading on gasket seat faces throughout circumference.

At the discretion of the end-user, stud bolting used for fixing larger valves may be subjected to tensioning prior to securing the valve.

4.6.2 **For Valves secured by Clamp Connectors** - Assemble seal ring into valve end face bore, offer up pipe flange to seal ring, secure with top and bottom clamp halves over hub ends, insert and tighten stud bolts – opposite corners – to ensure even clamping using the predetermined torque value – See clamp manufacturers instructions.

WE ADVISE THE REMOVAL OF THE EYEBOLT/S AFTER VALVE INSTALLATION

5. Proving

5.0. To ensure that the valve/pipe flange mating faces are correctly sealed, line pressure tests are to be carried out according to the valve size, pressure class, piping class and the service conditions of the line.

5.1. Direction of testing pressure is to be observed in relation to whether the valve disk should be open or closed position for upstream or downstream flow.

5.2. If, required, Electrical Continuity Tabs must be installed by user.

5.3. The temperature of the valve outer surfaces is determined by the media passing through the pipeline. It is the user's responsibility to ensure the correct materials of construction.

6. Maintenance Instructions

Annual checks for wear & corrosion should be carried out on all parts, and any affected parts should be replaced immediately.

6.1. Dismantling Valves **without external** hinge and stop pin retailers ('BR' / 'BFR' / BSR' / 'BHR' Style).

6.1.1 **CAUTION! THE SPRING IS UNDER TENSION.**

6.1.2 Lay the valve flat with spring uppermost. Record and mark each valve disc to enable them to be reassembled in their original location

6.1.3 Remove the 4 grub screws in the front face (BR10)

- 6.1.4 Knock out the keeper plates (BR08)
- 6.1.5 Lift the whole out of the valve internals y lifting the stop pin vertically.
- 6.1.6 Place the disc assembly flat at the side of the body and remove the carriers (BR06) from the ends of the hinge pin & stop pin (BR03)
- 6.1.7 Apply a vertical force downwards on the tensioned spring to hold it in position. Slide the hinge pin & stop pin (BRO3) out of the spring coils.
- 6.1.8 Gently release the force on the spring (BO4) until free and then remove.
- 6.2. Assembly of valves **without external** hinge and stop pin retainers ('BR' / 'BFR' / 'BSR' /'BHR' Style).
 - 6.2.1 Ensure all components are clean and are without unusable wear marks.
 - 6.2.2 Lay the valve body flat with the carrier slots uppermost
 - 6.2.3 Position the two valve discs (BO2) correctly as marked according to 6.1.2 at the side of the body and insert the hinge pin (BR03) through the ears to align them.
 - 6.2.4 Lay the spring in the 'Vee' between the plates – See *Figure 1*.

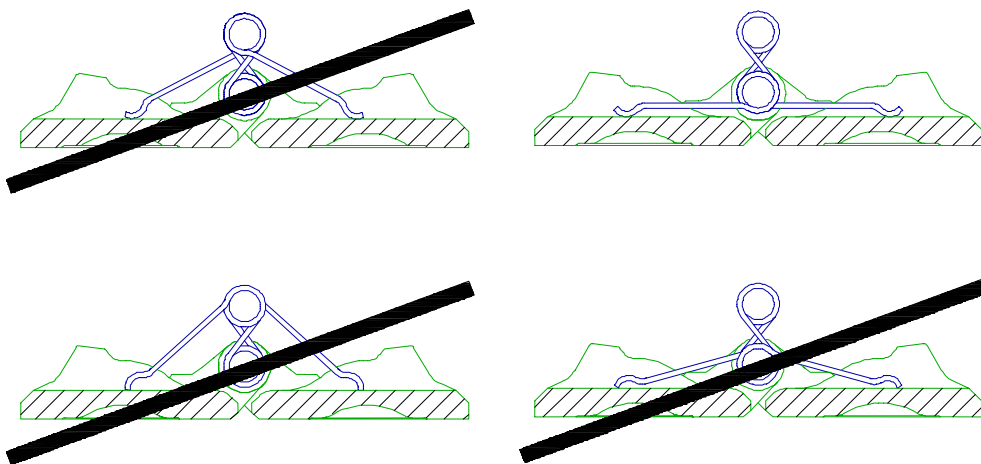

Figure 1

- 6.2.5 Apply the force to the spring (BO4) to keep it in position and rotate the top leg through 180 degrees such that the "heel" of the leg remains nearest the discs (B02) through its movement – See *figure 1*.
- 6.2.6 Still holding the spring (BO4) in place, insert the hinge pin (BR03) through the discs and spring until the spindle is fully secured in both sides of the discs (B02).
- 6.2.7 Insert the stop pin (BR03) into position through the upper coils of the spring (BO4).
- 6.2.8 Position the carriers (BR06) onto the ends of the pins making sure that the chamfered end of the carrier is at the hinge pin end.

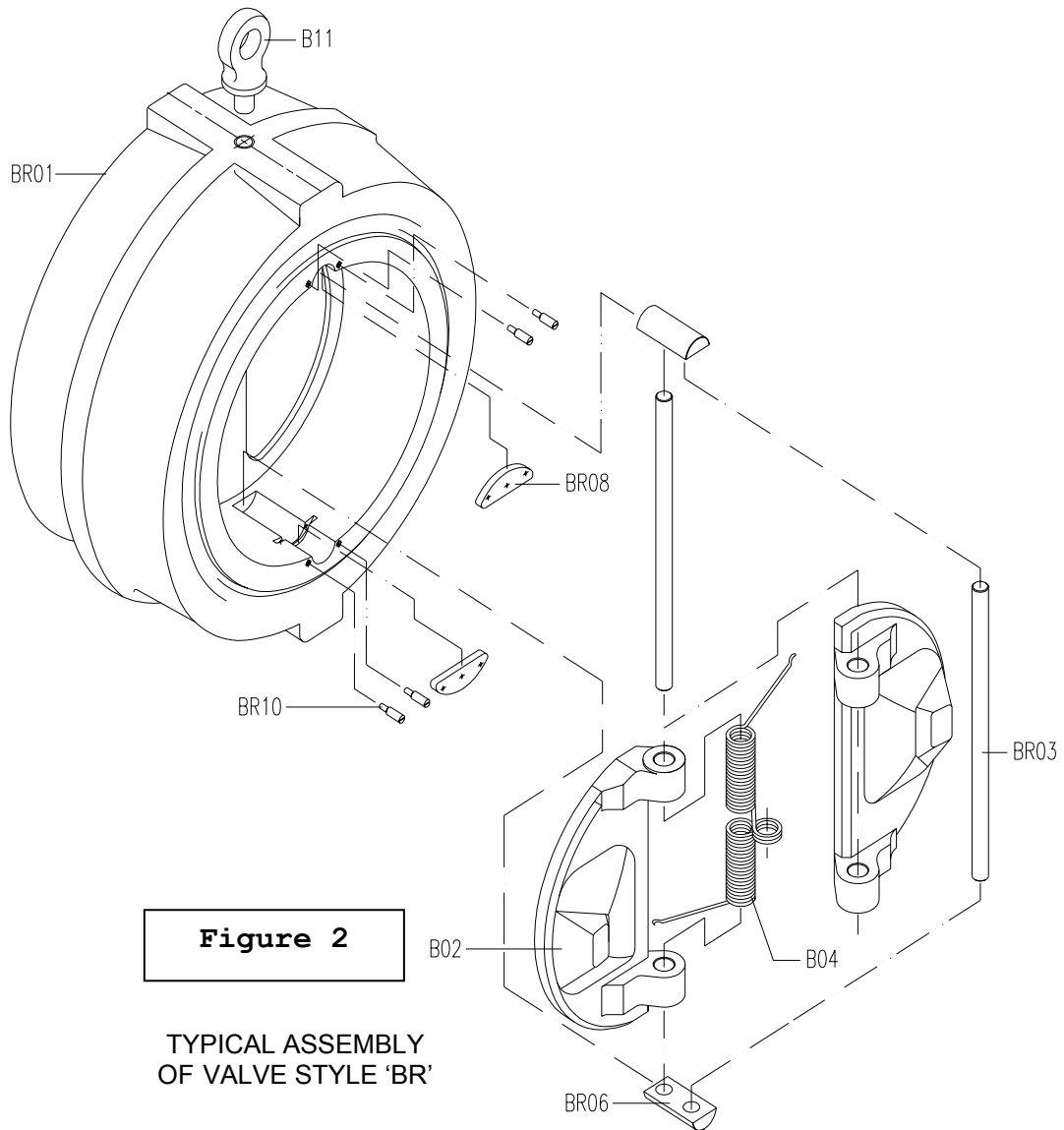

Figure 2

TYPICAL ASSEMBLY
OF VALVE STYLE 'BR'

- 6.2.9 Lift the assembly and lower it into the valve body. Insert the keeper plates (BR08) into the slots above each carrier and align the grub screw holes. Screw in the grub screws (BR10) until they are below the face of the valve.
- 6.3. Dismantling Valves **with external** hinge and stop pin retainers ('B' / 'BF' / 'BS' / 'BH' Style).
- 6.3.1 **CAUTION! THE SPRING IS UNDER TENSION.**
- 6.3.2 Lay the valve flat with spring uppermost. Record and mark each valve disc to enable them to be reassembled in their original location.
- 6.3.3 Remove the 2 hinge pin retainers & 2 stop pin retainers (B07)
- 6.3.4 Knock out the stop pin & withdraw completely (B03)

- 6.3.5 Apply a vertical force downwards on the tensioned spring to hold it in position. Knock out the hinge pin & withdraw completely (B03)
- 6.3.6 Gently release the force on the spring (B04) until free and then remove.
- 6.3.7 Lift out 2 discs (B02) and spacer washers (B05)
- 6.3.8 Remove 4 graphite gaskets from the bottom of the screwed retainer holes (B14)
- 6.4. Assembly of Valves **with external** hinge and stop pin retainers ('B' / 'BF' / 'BS' / 'BH' Style).
 - 6.4.1 Ensure all components are clean and are without unusable wear marks. It is essential to remove all traces of sealing compound from the hinge & stop pin retainers (B07) if they are being re-used, along with the tapped holes in the body. Should either retainer or hole threads be damaged the component is un-useable.
 - 6.4.2 Lay the valve body flat with the stop pin holes uppermost.
 - 6.4.3 Position the two valve discs (B02) and spacer washers (B05) correctly as marked according to 6.3.2 on the body seat faces and insert the hinge pin (B03) through the ears to align them.
 - 6.4.4 Withdraw the hinge pin sufficiently far enough to position the spring (B04)
 - 6.4.5 Lay the spring In the 'Vee' between the Plates – See *Figure 1*.

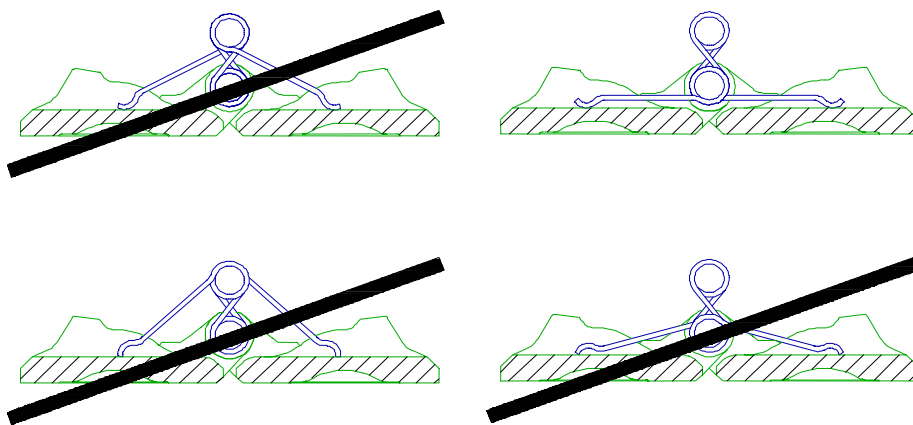
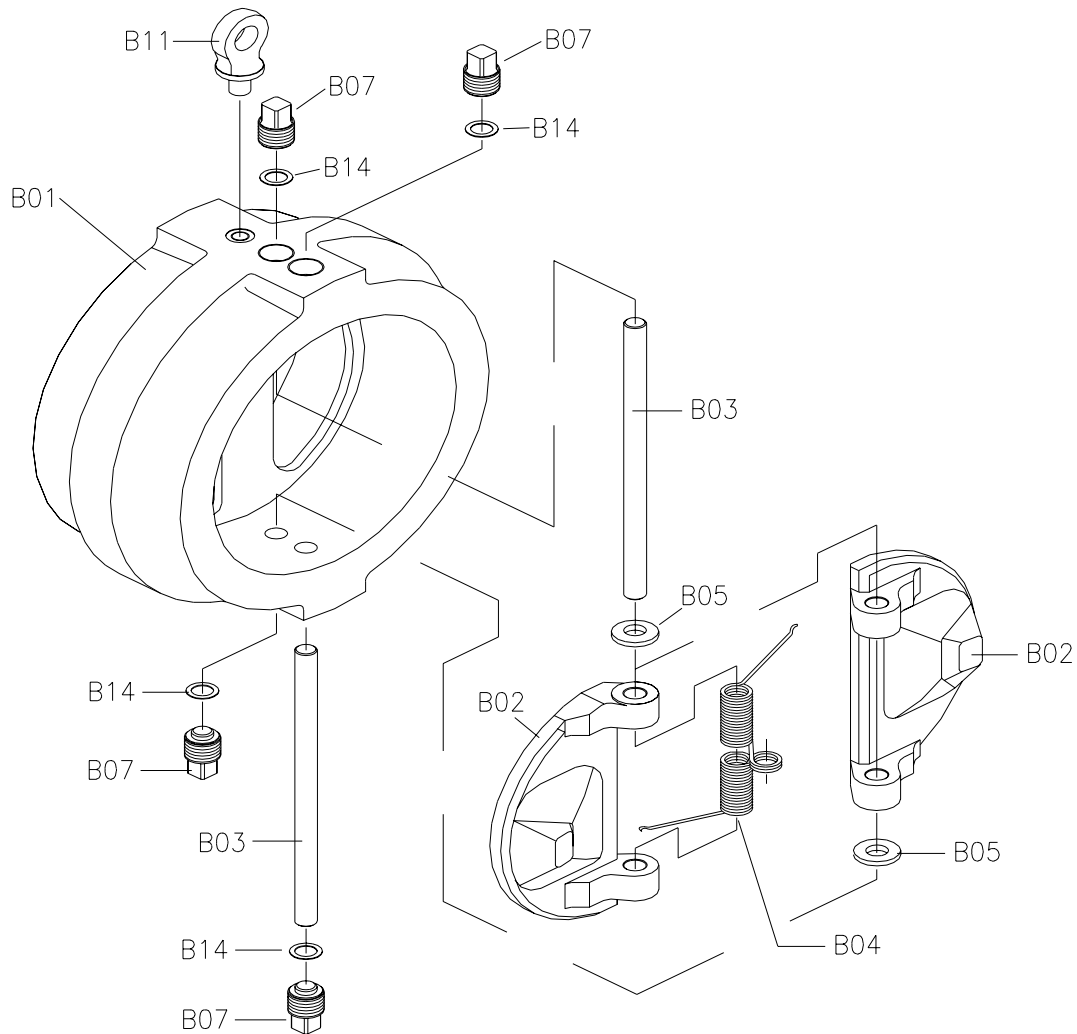

Figure 1

- 6.4.6 Apply force to the spring (B04) to keep it in position and rotate the top leg through 180 degrees such that the "heel" of the leg remains nearest the discs (B02) through its movement – See *Figure 4*.
- 6.4.7 Still holding the spring (B04) in place, insert the hinge pin (B03) through the body, discs and spring until the spindle is fully secured in both sides of the body.

- 6.4.8 Insert the stop pin (B03) into position through the body (B01) & upper coils of the spring (B04).
- 6.4.9 Apply a liquid jointing compound to the threads of all the screwed retainers (B07) ensuring that the compound selected is compatible with the flow line media. **NOTE.** PTFE tape **MUST NOT** be used.
- 6.4.10 Place a graphite gasket (B14) in the bottom of each screwed retainer hole, and screw down each retainer tightly.



TYPICAL ASSEMBLY OF
VALVE STYLE 'B'

Figure 4

7. Inspection

- 7.1. Turn the valve onto its side and confirm free movement of both plates.
- 7.2. When fitting the above valves into their respective pipeline positions ensure that stopping is vertical as described in paragraph 4.2. (Always use the eyebolts provided with the valve)

8. Testing

After assembly and inspection all units shall be pressure tested in accordance with API 598 as a minimum or to attached label. Test pressures are shown below.

HYDROSTATIC SEAT TEST						
MATERIAL	SEAT TEST PRESSURES BY CLASS PSIG					
CLASS	150	300	600	900	1500	2500
ASTM A216 WCB ASTM A350 LF2	325	825	1650	2450	4100	6800
ASTM A352 LCC ASTM A217 CA15 S31254 S31803	325	825	1650	2475	4125	6875
ASTM A351 CF8M	325	800	1600	2400	3975	6600
BS 1400 AB2	325	825	-	-	-	-
TITANIUM	325	-	-	-	-	-

HYDROSTATIC SHELL TEST						
MATERIAL	SHELL TEST PRESSURES BY CLASS PSIG					
CLASS	150	300	600	900	1500	2500
ASTM A216 WCB ASTM A350 LF2	450	1125	2225	3350	5575	9275
ASTM A352 LCC ASTM A217 CA15 S31254 S31803	450	1125	2250	3375	5625	9375
ASTM A351 CF8M	425	1100	2175	3250	5400	9000
BS 1400 AB2	450	1125	-	-	-	-
TITANIUM	450	-	-	-	-	-

9. Paint.

Apply paint in accordance with the project specification and service conditions.