



R4TM
Red
Round
Rotary
Reliable

Electric Actuator

SERIES 40

RUGGED ELECTRIC ACTUATOR FOR ROTARY VALVES

300 TO 6,500 LB-IN OUTPUT TORQUE

Bray Valve & Controls' years of proven success in electric actuation, combined with innovative engineering, has produced the R⁴. The R⁴ features on-off or modulating control. This red, round electric actuator for rotary valves delivers highly reliable service.

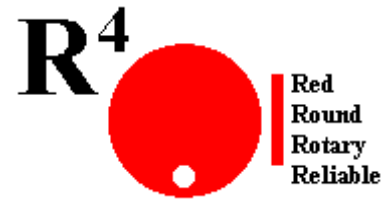

Bray's unique, customer-friendly designed Control Center has many advantages over present industry standards including:

- Ease of customer field wiring directly to the terminal strip without interference from other components.
- Simple and unique manual override handwheel system
- Lowest profile and lightest weight actuator on the market.
- Simple finger or screw driver adjustment of travel limit cams without interference from other components.
- Highly visible valve status display.
- Externally adjustable travel stops.
- Captive housing screws.
- Special features: SPDT-DB travel switches.

Additionally, components not requiring customer access are protected underneath the Power Center cover plate.



The Bray R⁴ Electric Actuator

The R⁴ compared to a typical actuator, both mounted to 4" Bray valves.

LOW PROFILE, COMPACT, HIGH TORQUE DESIGN

The R⁴ is by far the most compact, lowest profile design of any electric actuator delivering comparable torque output. Through research and many years of field experience have gone into the development of this state-of-the-art actuator - *the product of the future*. This design offers the advantages of greatly reduced space requirements, lighter weight and ease of installation and maintenance when compared to other electric actuators. When mounted directly to Bray valves, the R⁴ is especially compact.

DIRECT MOUNTING OF THE R⁴ ON BRAY VALVES

Bray actuators mount directly on to Bray valves without using any external linkage. Field installation is simple and misalignment is minimized. For sanitary processing and outdoor applications, the Bray direct mounting system reduces the possibility of contamination buildup or corrosion between the valve and actuator. The mounting pattern complies with ISO 5211 and VDI/VDE 3845 (NAMUR recommendations). The R⁴ can be mounted and operated in any position. Standard rotation is 90 degrees reversible. Extended rotation units such as 180, 270 degrees or beyond are optional. Bray can provide linkages for mounting the R⁴ to other devices requiring 90 degrees rotation. Please consult the Bray factory for further information.

EXTERIOR FEATURES

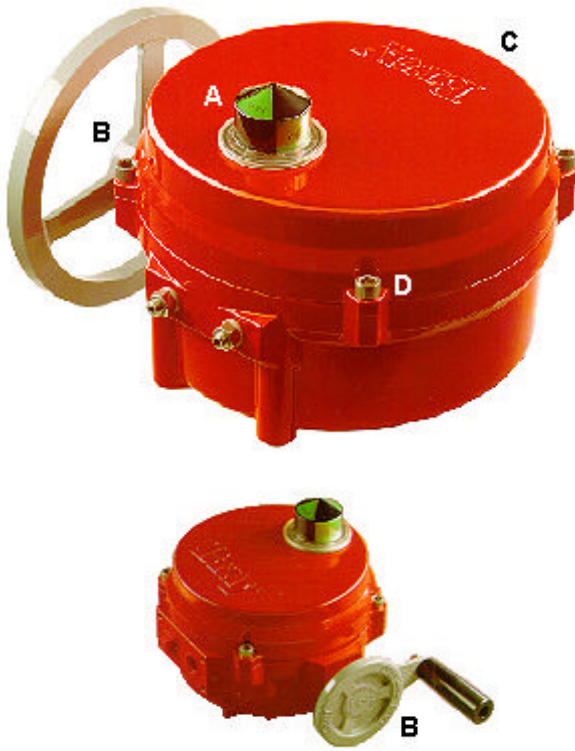

VALVE STATUS DISPLAY (A)

The R4 features a highly visible valve status display. Prominently labeled and color coded - green for open, red for closed - the display indicates valve position through the full range of travel. The display can be locally seen from almost any angle. Made of high impact, heat and chemical resistant clear polycarbonate, this display withstands caustic washdown and offers excellent corrosion protection.

MANUAL OVERRIDE (B)

A manual override handwheel is standard on all models to rotate the valve without electrical power. A yellow caution stripe around the handwheel hub indicates the handwheel is engaged for manual operation.

ENCLOSURE (C)

Die-cast aluminum cover and base are waterproof (NEMA-4, 4X, IP 65) and high-quality polyester powder coated for exceptional corrosion, wear, impact and ultra-violet resistance. Potential leak paths are eliminated since the indicator shaft does not protrude through the enclosure.

CAPTIVE COVER BOLTS (D)

The cover is attached to the base by stainless steel bolts. When the cover is removed the bolts are held captive in the cover. This prevents time consuming problems caused from lost or misplaced bolts.

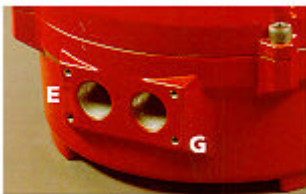

CONDUIT ENTRIES (E)

For ease of field wiring, the R4 features two conduit connections in either NPT or metric threads. One entry is for power wiring, one for control wiring.

ELECTRICAL CABLE CONNECTIONS (F) (Optional)

A multi-pin, watertight electrical cable connector is designed for full compatibility with today's industrial wiring requirements. Standardized factory pre-wiring prevents wiring errors and provides quick-connect field installation. We offer two types of connections for wiring to the power supply: a Cordset with cable connection to match the pins of the R4 and flying leads to the power supply, and an Extension Cord/ Receptacle with connections on both ends with receptacle at power supply.



TAPPED HOLES FOR LOCAL CONTROL STATION MOUNTING (G)

The conduit entry panel has four tapped holes for ease of installation of an optional local Control Station.

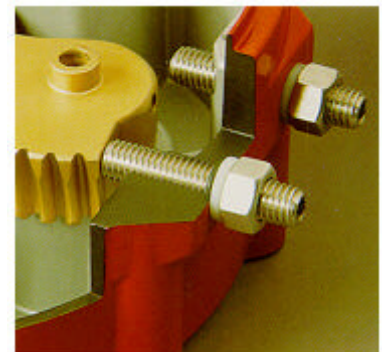

MECHANICAL TRAVEL STOPS

Stainless steel mechanical travel stops permit precise field adjustment of actuator movement to specific degrees of rotation. The travel stops are located outside the base for easy readjustment without removing the cover. When adjustment has been made, stainless steel lock nuts with O-ring seals hold the travel stops securely in place. The travel stops are normally set at the factory for 0° and 90° of travel, however additional fine adjustment may be made in the field.



CONTROL CENTER

CLEAN AND EASY ACCESS TO ALL FIELD WIRING AND ADJUSTMENTS

Bray has specifically engineered the R4 Control Center for customerfriendly convenience. Designed like a junction box, the R4 offers by far the easiest access to terminal block wiring, cam adjustments and switch installation. Accessories are easily added, either before installation or after installation. Therefore, the timerequired for field start-up and adjustment is greatly reduced, and maintenance can be performed with assured ease and safety.

Bray's unique design, modular system of components and accessories, and innovative features combine to best meet today's industrial requirements.

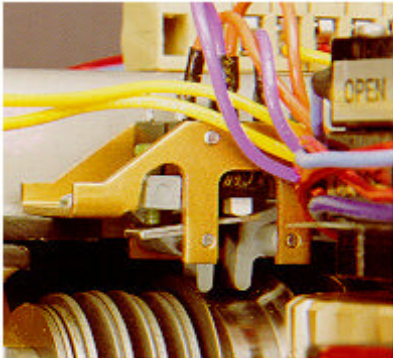

TORQUE LIMITING SWITCHING SYSTEM (Optional)

The torque limiting switching system consists of two SPDT-DB mechanical switches and two factory calibrated adjusting screws. The green screw adjusts the torque limit in the open direction, and the red screw adjusts the torque limit in the closed direction. The switches independently respond to predetermined loads in both the open and closed travel directions by sensing the movement of the worm shaft, and inter-

rupting the electrical power to the motor. The switches can operate at any point of actuator travel.

CONTROL CENTER FEATURES

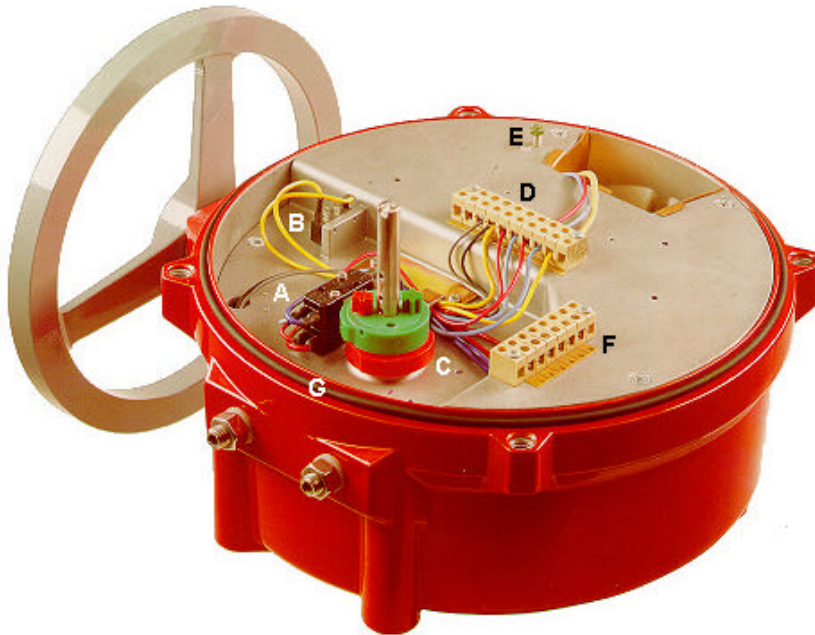

TRAVEL LIMIT SPDT-DB SWITCHES (A)

Bray has provided two SPDT-DB switches as standard. One SPDT-DB (double break) switch provides two independent electrical circuits, similar to two SPDT switches. This feature allows one side of the switch to be used for AC motor control, and the other side of the switch to be used for a completely independent purpose, i.e. to switch a low voltage AC lamp or a DC computer input. This switch combination is used for both open and closed positions of the valve and requires only one cam for each direction of valve travel. Bray's design eliminates the need for 4 SPDT switches and 4 cams commonly used in these applications, and provides synchronicity between motor control and position display. Switches are easily accessible without interference from other components. Each switch is marked with open or closed labels and the cams are color coded, eliminating the possibility of making wrong adjustments of travel limits or field wiring errors.

AUTOMATIC POWER CUTOFF SWITCH (B)

The R4 is supplied with a SPDT-DB mechanical switch which cuts power to the motor when the hand-wheel is engaged for manual operation. This switch also functions as a safety emergency shutdown device that immediately stops the actuator even if electrical power is still being applied to the unit.

CAMS / CAM ADJUSTMENT (C)

Bray's patented cam design is an outstanding feature of the R4. Cams for each switch are *infinitely* adjustable by finger touch or screwdriver with no special tools needed. The adjustment knobs rotate the specifically formed cams. Each cam is color coded - the red adjustment knob drives the red cam (which closes valve,) and the green knob drives the green cam (which opens valve.) Standard factory setting allows 90 degrees of travel between open and closed positions.

TERMINAL BLOCK (D)

The actuator switches are prewired to a terminal

R4 APPLICATIONS

The R4 is the ideal choice for process control applications involving:

- Automation and computer systems.
- Butterfly, ball, plug and other rotary valves.
- Dampers, switches, safety and flow-control devices.
- Machine and fixture indexing.
- Hostile environments demanding excellent moisture, chemical and corrosion resistance.
- Long service life and rugged reliability.

INDUSTRIES

Bray's R4 Electric Actuators are used in a wide range of industries world wide, including: Chemical, Pharmaceutical, Petroleum Refining and Oilfield, Microelectronics, Pulp and Paper, Water and Waste Water Treatment, Brewing, Food Processing, Beverages, Power, Marine,

block. The block has been designed for ease of customer wiring without interference from other components and features clearly marked wire numbers. The block has been placed near the two conduit entries with ample room for running wire leads. A wiring diagram is included inside the cover for easy reference. The **ground wire screw (E)** is painted green and positioned for visibility. The **terminal block (F)** is for Bray factory wiring and limit switch field wiring.

O-RING SEAL FOR WATERTIGHT ENCLOSURE (G)

The large seal between the cover and base provides a waterproof enclosure and prevents internal corrosion. The Bray R4 O-ring seal is the best design for watertight enclosures and is far superior to commonly used gaskets.

HEATER (Optional)

Pre-wired to the terminal block, a thermostatically controlled heater prevents condensation from collecting inside the actuator, which could cause damage to the electrical components. The heater is mounted below the switch plate. Heaters are ideal for use in applications with extremely wide temperature or humidity ranges.

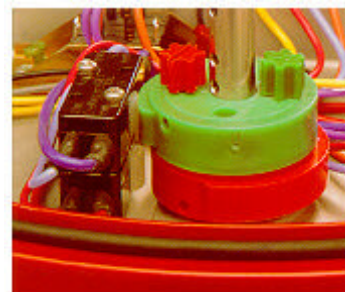

POWER CENTER

Bray designed the R4 to completely separate the Control Center from the Power Center. The Power Center, located in the actuator base, consists of motor, gear train, capacitor, output drive and heater. This design protects the power drive system as each component has been engineered to require no customer servicing. The Power Center components have been uniquely configured to maintain the extremely low profile of the R4.

MOTOR (A), CAPACITOR (B) AND SPUR GEAR (C) SYSTEM

The R4 has a 120 or 220 VAC single phase permanent split-capacitor reversible induction motor. The motor features a built-in thermal overload protector of a bi-metallic strip in windings set at 338 degrees F (170 C) with automatic reset. The heavy-duty spur gear train is composed of precision cut, multi-staged gears and shafts. The gears and shafts are heat treated high alloy steel and will withstand locked rotor conditions. The spur gear train is permanently lubricated at the factory. This gear train drives the worm shaft which in turn drives the segmented worm gear output shaft.

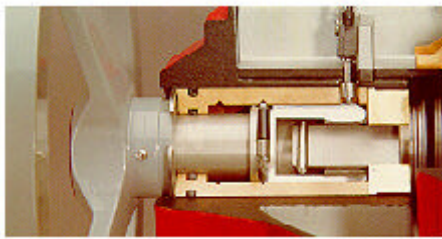
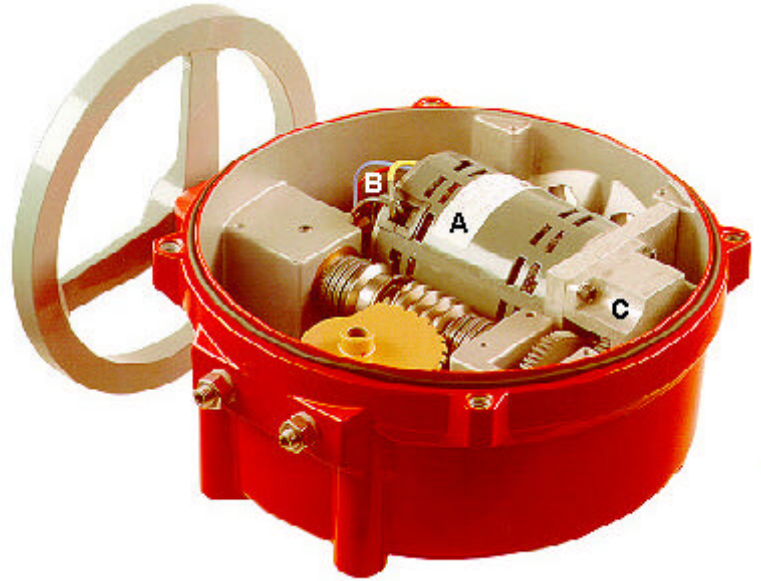

Left photograph is sectional view of the manual override assembly with override disengaged.

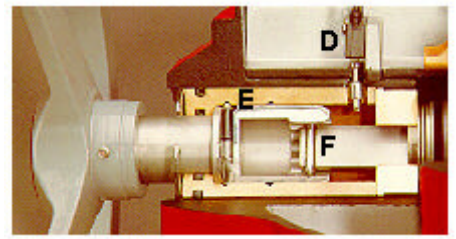

Photograph to right shows manual override engaged.

MANUAL OVERRIDE HANDWHEEL ASSEMBLY

- Pull to engage for manual operation.
- Rotate handwheel to position valve.
- Push to disengage for power operation.

A simple pull engages the handwheel for manual operation. The Bray manual override system ensures positive and fast manual operation without the use of extra tools or levers. When the handwheel is engaged, the electrical power to the motor is cut off by means of the Automatic Power Cutout Switch (D). When engaged, the manual override shaft is held in position by a Ball Detent (E). The Ball Detent also holds the shaft in position when the handwheel is pushed in to disengage the override. The Drive Pin (F) engages and disengages the manual override shaft from the worm and segmented worm gear output shaft. When the handwheel is pushed or pulled, the drive pin smoothly engages the worm shaft.

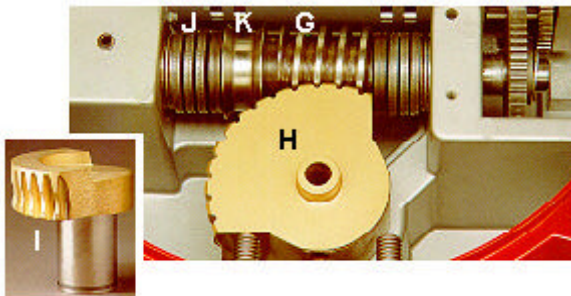

SELF-LOCKING OUTPUT DRIVE ASSEMBLY

The output drive assembly features a self-locking worm and worm gear drive which holds the valve in the desired position without the need for electromechanical braking systems. The worm shaft directly drives the worm gear. The Worm (G) is made of chrome-moly steel and the segmented Worm Gear (H) is a precision machined aluminum bronze casting. The worm gear is cast around the stainless steel Output Shaft (I) to become one part. The output shaft is the driving member that positions the valve. The worm gear drives the valve status display shaft which operates the infinitely adjustable cams to limit the electrical travel of the actuator.

MECHANICAL TORQUE LIMITING SYSTEM (Optional)

The mechanical torque limiting system consists of a Worm Shaft, A Worm (G), a set of Torque Disc Springs (J) and a Shaft Groove (K) for torque limiting switches. The torque disc springs, located on each side of the worm, resist the linear movement of the worm shaft. The worm shaft is driven against the torque disc springs in response to output torque. The shaft groove actuates the torque limiting switches, located above in the Control Center, to start and stop the motor. (Please refer to the Control Center section for description of the Torque Limiting Switching System.) The precisely controlled movement of this system is the main torque limiting element of the R4.

MODULATING ACTUATOR FOR PRECISION CONTROL OF VALVE POSITION

The R4 Electric Actuator can be equipped with a Servo for precise control of valve position. The Servo consists of a circuit board and a feedback potentiometer assembly, which both fit entirely within the standard R4 actuator housing. The circuit board has a single terminal block for customer field wiring, and other terminals for internal connections to the actuator components. The feedback potentiometer is driven by a gearset connected to the actuator output drive.

SERVO OPERATION

The Servo can be easily configured by the factory or the customer to accept several types of input signals, such as 4-20 mA DC, 0-10 VDC, 2-10 VDC or potentiometer control. The input signal electronically represents the *desired* actuator position, and the feedback potentiometer signal electronically represents the *actual* actuator position. The circuit board constantly compares the two signals, and if a difference is detected, drives the actuator in the proper direction until the signals are equal. When a balance is reached, the circuit board turns off the actuator motor. The worm gear then mechanically holds the valve in the desired position until

SPEED CONTROL

Adjustments are provided for both open and closed speed control of the actuator motor. In addition, an approach control circuit senses when the actuator is about to reach the desired valve position, and pulses the motor to avoid overshooting the set-point.

SERVO VOLTAGE SPIKE PROTECTION

Voltage spikes that can damage electrical equipment are very common in industrial locations. Large voltage spikes can be caused by interrupting the current to the actuator motor when the travel limit is reached. The output stage TRIACs of the Servo are protected against damage from voltage spikes by a special combination of:

- limit switch circuitry
- zero crossing detection

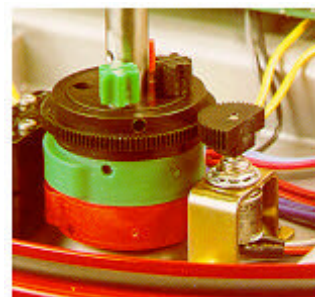

Feedback Potentiometer Gear

POTENTIOMETER CALIBRATION

Calibration of the feedback potentiometer is done through a unique gear arrangement that is easily accessible and eliminates the need of any special tools to make required adjustments. A simple adjustment of Bray's patented cam drive aligns the potentiometer as easily as a travel cam.

Also, the feedback potentiometer gear is specially shaped to disengage when the limits of the active region of the potentiometer are exceeded. This situation can occur when the manual override handwheel is turned past 90 degrees or below 0 degrees travel. The special gear prevents damage to the potentiometer from over rotation, and provides an easy reference for recalibration. Returning the actuator to the fully open or closed position and remeshing the potentiometer gears restores the proper alignment.



Control Station

SERVO SPECIFICATIONS

NOTE: Servo is available for modulating service- continuous duty actuators only.

NOTE: "Standard" is the way the servo is set at the factory. "Configurable" means the customer, or the factory, can modify the Servo simply by moving switches, jumpers, etc.

Power Input:	115 VAC, 60 Hz (Standard)
	230 VAC, 50 Hz (Configurable)
Power Consumption:	2 Watts (not including actuator power)
Input Signal:	4-20 mA DC into 250 Ohm (Standard)
	0-10 VDC (Configurable)
	2-10 VDC (Configurable)
	135 Ohm or greater potentiometer (Configurable)
Calibration:	Circuit board: Zero, Span, Deadband, Open Speed, Close Speed
	Feedback: Potentiometer Drive Gear
Temperature Rating:	-40°F (-40°C) to 160°F (70°C)
Indicators:	Power (Yellow LED)
	Open Drive (Green LED)
	Close Drive (Red LED)
Control Characteristic:	Linear
Duty Cycle:	100%
Internal Feedback:	5 kOhm Potentiometer, gear driven

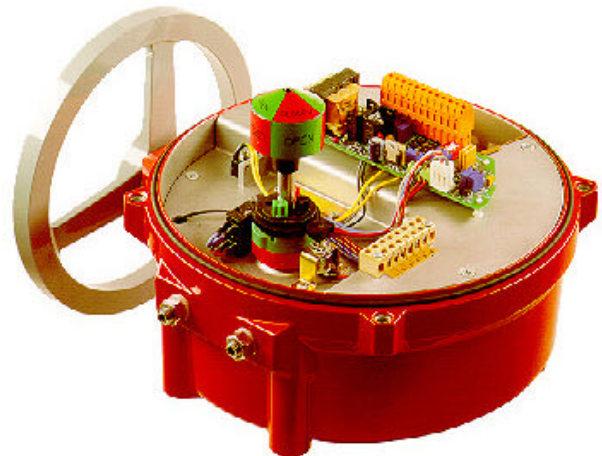

CONTROL STATION (Optional)

Bray has designed a manual local electrical control station that flush mounts directly to the R4.

The control station features:

- a local and remote control switch
- an open-stop-close switch
- two lights which locally indicate open and closed valve position.

The cover plate can be rotated in any 90 degree increment, allowing the customer to operate and view the station with ease. The enclosure is aluminum and weatherproof (NEMA 4, 4X, IP 65.) Additionally, the control station has captive cover bolts and two input connections available in the following thread connections: 3/4" NPT, M25 or PG16.

The control station is available with two different multi-pin, watertight electrical cable connections as previously stated.

DIMENSIONS

Actuator Size	A	B	C	D	E	F	G	H	J	K(UNC) x B.C.	M(UNC) x B.C.	N	P	Q
S70-003 S70-005	7.5 [191]	5.6 [142]	3.0 [76]	5.1 [130]	1.9 [48]	1.94 [49.3]	.19 [4.8]	1/2 *	2.0 [51]	5/16-18 x Ø2.76	-	.75 [19]	.51 [13]	1.47 [37]
S70-008 S70-012 S70-020	10.1 [257]	7.8 [198]	3.7 [94]	6.5 [165]	2.5 [64]	2.69 [68.3]	2.5 [64]	3/4 *	2.6 [66]	5/16-18 x Ø2.76	1/2-13 x Ø4.92	1.18 [30]	.87 [22]	1.82 [46]
S70-030 S70-050 S70-065	12.1 [307]	9.5 [241]	5.6 [142]	7.2 [183]	2.9 [74]	3.19 [81]	.56 [14.2]	3/4 *	3.1 [79]	1/2-13 x Ø4.92	5/8-11 x Ø6.50	See Detail A		

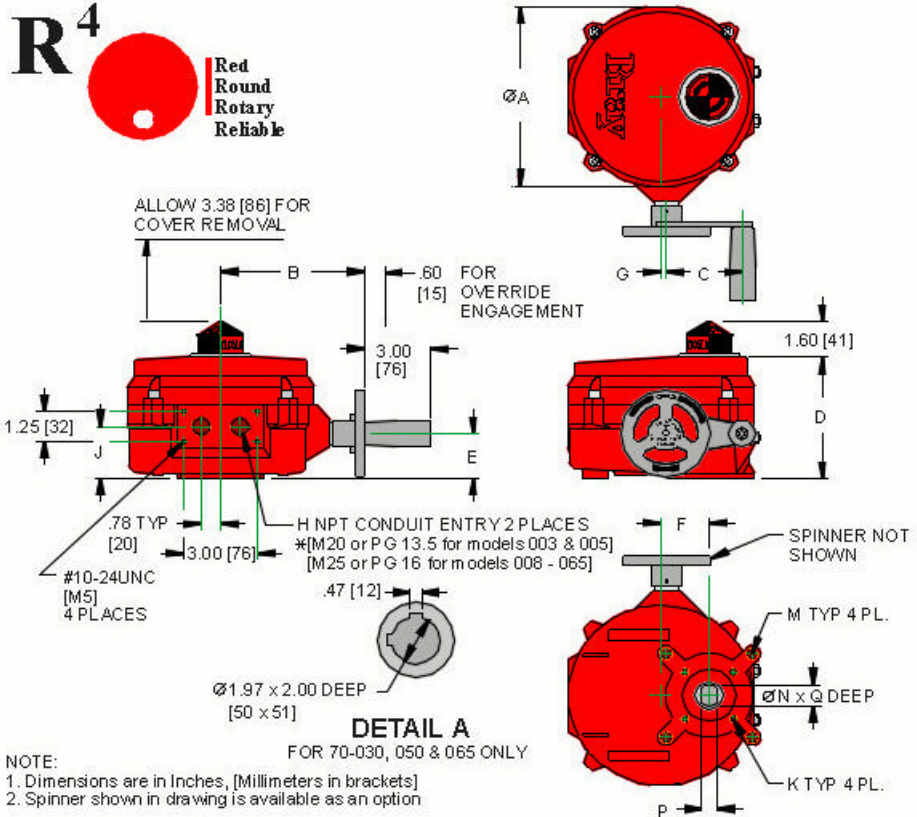

24 VDC available as an option, please consult your Bray representative or the factory.

** The duty cycle for intermittent on-off operation is 25%. The continuous duty actuator with Servo is rated for 100% modulating operation at an ambient temperature of 104°F (40°C.)

Actuator Series	Torque Output Lb/in [Nm]	Single Phase Motors Current Rating (Amps At all Speeds (locked rotor))			Speed For 90° Operation In Seconds/Total Gear Ratio						Rim Pull lbs [kgs]	Bray Valve Sizes For Direct Mounting	Weight lbs [kgs]
		VAC	Hz	Amps	On-Off Intermittent**		Modulating Continuous**		Manual Override				
					Optional Speeds	Standard Speeds	Optional Speeds						
S70-003	300 [34]	120	50/60	1.4		8 sec. 1,392:1	15 sec. 2,413:1	30 sec. 5,070:1	60 sec. 11,200:1	30:1	11.4 [5]	2" thru 6"	12 [6]
		220	50/60	0.6									
S70-005	500 [57]	120	50/60	0.8			15 sec. 2,413:1	30 sec. 5,070:1	60 sec. 11,200:1	30:1	19.0 [9]	2" thru 6"	12 [6]
		220	50/60	0.5									
S70-008	800 [90]	120	50/60	2.1	6 sec. 681:1	10 sec. 1,080:1	15 sec. 1,640:1	30 sec. 3,340:1		30:1	13.0 [6]	2" thru 12"	28 [13]
		220	50/60	0.9									
S70-012	1200 [136]	120	50/60	2.1		10 sec. 1,080:1	15 sec. 1,640:1	30 sec. 3,340:1		30:1	20.0 [9]	2" thru 12"	28 [13]
		220	50/60	0.9									
S70-020	2000 [226]	120	50/60	2.1			15 sec. 1,640:1	30 sec. 3,340:1		30:1	33.0 [15]	2" thru 12"	28 [13]
		220	50/60	0.9									
S70-030	3000 [339]	120	50/60	3.0			18 sec. 2,080:1	30 sec. 3,340:1		30:1	33.0 [15]	8" thru 20"	48 [22]
		220	50/60	1.4									
S70-050	5000 [565]	120	50/60	3.0			18 sec. 2,080:1	30 sec. 3,340:1		30:1	55.0 [25]	8" thru 20"	48 [22]
		220	50/60	1.4									
S70-065	6500 [734]	120	50/60	3.0				30 sec. 3,340:1		30:1	72.0 [33]	8" thru 20"	48 [22]
		220	50/60	1.4									

TYPICAL WIRING DIAGRAMS

Wiring Diagrams are for
REFERENCE ONLY
Do NOT use for field wiring

ON - OFF With Optional Torque Limit Switches, Heater and Auxiliary

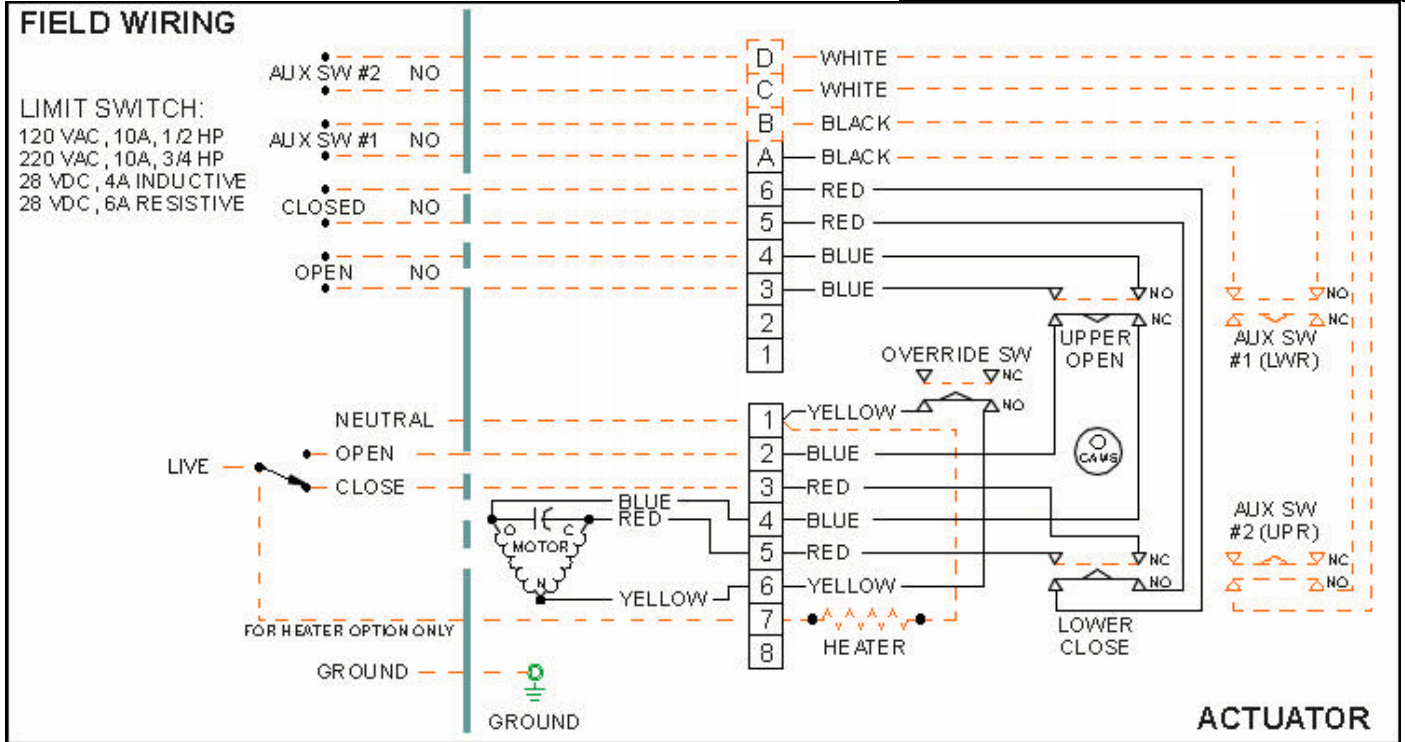

MODULATING - SERVO With Optional Torque Limit Switches and

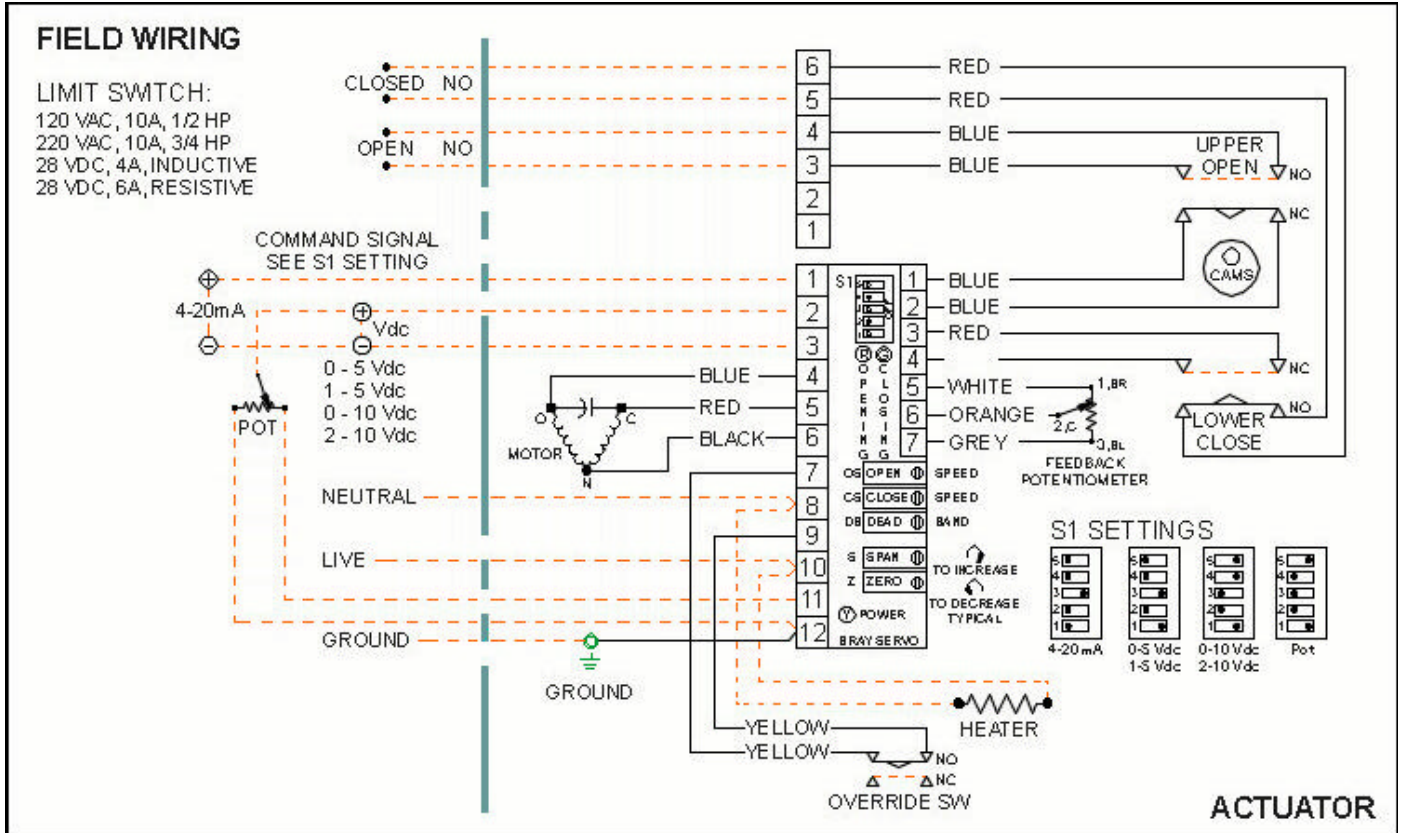

NOTES:

- 1) Actuators are shown in closed position.
- 2) Manual Override is not engaged.
- 3) Heater is optional
- 4) All switches are Single Pole, Double Throw, Double Break.
- 5) Terminal block accepts field wiring from 1022 AWG. 12-22 AWG for Servo.

SPECIFICATIONS

The electric actuator shall be compact and low-profile to greatly reduce space requirements. The actuator shall feature ease of access to field wiring and adjustment. The actuator shall be built to withstand line vibration and shock without failure and shall bolt directly to Bray valve mounting flanges without using brackets.

MOTOR

A single phase permanent split-capacitor reversible motor with voltages of 120 and 220 VAC 50/60 Hz shall be standard. Motor insulation shall be Class F or better. The motor shall contain a built-in thermal overload protector of a bi-metallic strip in windings set at 338°F (170°C) with automatic reset. DC motors shall be available upon request.

DUTY CYCLE

The duty cycle for intermittent on-off operation shall be 25%. The continuous duty actuator with Servo shall be rated for 100% modulating operation at an ambient temperature of 104°F (40°C).

SPUR GEAR TRAIN SYSTEM

The actuator shall have a self-locking gear output drive mechanism. The spur gear train shall have precision cut multi-staged gears which will withstand locked rotor conditions. The spur gear train shall be permanently lubricated at the factory. The gear train shall drive a chrome-moly steel worm which drives the composite aluminum bronze segment gear / stainless steel output shaft.

WIRING

Actuator switches shall be pre-wired to a terminal block for ease of access and all internal wiring shall range from 10-22 AWG.

SWITCHES

All travel switches shall be Single Pole, Double Throw, Double Break Form Z type 10A at 125/250 VAC, 4A at 28 VDC inductive load, 6A at 28 VDC resistive load, UL and CSA approved. Travel Limit switches shall limit actuator in both the open and closed position of valve travel.

CAMS

Cams for each travel limit switch shall be infinitely adjustable by finger touch or screw driver, as provided by Bray's patented design.

CONDUIT ENTRIES

All units shall have 2 conduit entries. Conduit entries for models 003 and 005 shall be either 1/2"NPT, M20 or PG13.5. Conduit entries for models 008-065 shall be

MECHANICAL TRAVEL STOPS

Mechanical stainless steel travel stops shall be located outside the actuator for ease of adjustment and contain stainless steel lock nuts with O-ring seals to hold the travel stops in place. The travel stops shall limit the actuator movement to specific degrees of rotation.

MANUAL OVERRIDE

All units shall be equipped with an aluminum manual override handwheel to rotate the valve without electrical power. The override assembly shall ensure positive and fast manual operation without the use of extra tools or levers.

EMERGENCY SHUT-OFF

An automatic power cutout switch shall be provided to cut power to the motor when actuator handwheel is engaged for manual operation. This switch shall function as a safety emergency shutdown device.

ENCLOSURE

The die-cast aluminum enclosure shall be waterproof (NEMA 4, 4X, IP65) rated and high-quality polyester powder coated for exceptional corrosion, wear, impact and UV resistance. The enclosure cover shall have captive cover bolts therefore preventing time consuming problems due to lost or misplaced bolts.

VALVE STATUS DISPLAY

The actuator shall have a highly visible clear polycarbonate display prominently labeled and color coded to indicate valve position throughout the full range of travel.

TEMPERATURE RATING

Actuators shall be designed for temperature

OPTIONAL EQUIPMENT

The actuator shall be designed to include any of the following accessories as an option.

TORQUE LIMITING SYSTEM

with 2 SPDT-DB mechanical switches and 2 factory calibrated adjusting screws - the green adjusts the limit in the open direction, the red adjusts the limit in the closed direction. The worm shaft is driven against the torque disc springs in response to the output torque. The switches contact the worm shaft groove in response to predetermined loads and interrupt the electrical power to the motor. The switches can operate at any point of actuator travel.

HEATER

With the thermostat control to prevent condensation buildup. The heater is pre-wired to the terminal block. Rated output is 15 W at 110 or 240 VAC.

SERVO

For precise modulating control of valve position. A solid state circuit board compares the input signal with the feedback potentiometer signal and drives the actuator until a balance is reached. The Servo has a specially shaped potentiometer gear which prevents damage due to over rotation and features voltage spike protection. Adjustments are provided for both open and closed Speed Control of the actuator. Input Signals: 4-20mA DC into 250 Ohm, 0-10 VDC, 2-10 VDC and 135 Ohm or greater potentiometer Adjustments: Zero, Span, Deadband, Open & Close Speed Internal feedback: 5 kOhm Potentiometer.

CONTROL STATION

For manual local electrical operation of the actuator. The Control Station flush mounts to the actuator and features a local and remote control switch, an open-stop-close switch, and two lights which locally indicate open and closed valve position. The enclosure is aluminum and weatherproof



The Bray R4™ Electric Actuator – Series 70-005, 065, and 020