

## Parallel Wiring

Do not parallel wire multiple actuators. Connecting more than one S70 actuator to a SPDT switch will interfere with motor performance. Voltage is present on both motor windings. These voltages are out-of-phase and different in magnitude. However, when electric actuators are connected in parallel, current flows from one actuator to the next. Use a multiple pole switch as shown in Figure 1.

FIGURE 1: MULTIPLE ACTUATOR (CORRECT) WIRING

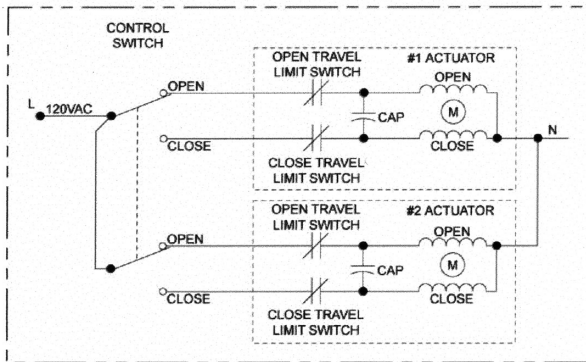

CORRECT

FIGURE 2: MULTIPLE ACTUATOR (INCORRECT) WIRING

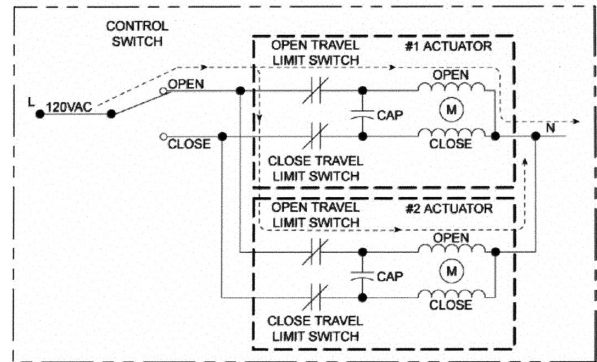

INCORRECT

## Instantaneously Reversing Motor Direction

Do not instantaneously reverse motors direction, if controlling actuator with relays (refer to diagram 1 for recommended control wiring or diagram 2 for alternate wiring) or a PLC, etc. Ensure a minimum of 0.5 to 1 second elapses between directional command changes. Actuator must have field wiring terminated as shown in the supplied wiring diagram (diagram attached to inside of cover). Wiring diagrams (AC or DC) show remote (customer supplied) typical control switching devices. Refer to customers' field wiring for details of the specific control devices.

DIAGRAM 1: RECOMMENDED (D.P.D.T RELAY)

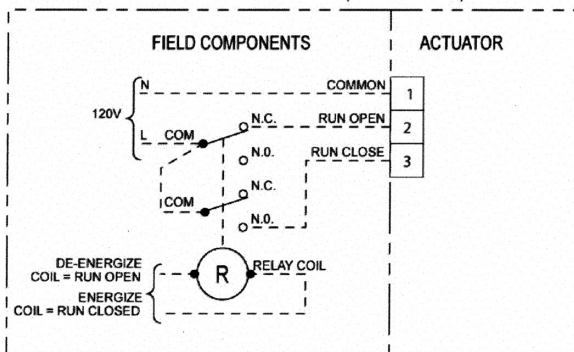
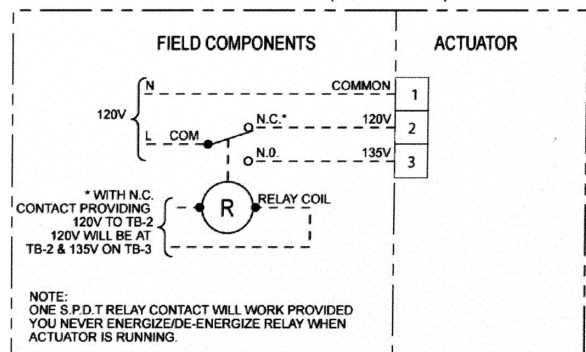

DIAGRAM 2: ALTERNATE (S.P.D.T RELAY)



The technical data herein is for general information only. Product suitability should be based solely upon customer's detailed knowledge and experience with their application.

All information herein is proprietary and confidential and may not be copied or reproduced without the expressed written consent of BRAY INTERNATIONAL, Inc.

