



ITT

Fabri-Valve®

Heavy Duty Knife Gate Valve



Engineered for life

Figure CF37

Revision 3

Fabri-Valve® CF37 Heavy Duty Knife Gate Valve



Figure C37 with energized cored packing.

Energized cored packing is standard with 6" (DN 150) and larger C37 valves and all F37 valves.

Fabri-Valve Figures C37 and F37 are some of the most popular knife gate valve configurations. Figure C37 knife gate valves through 24", feature a heavy duty, rugged one-piece cast body, chest and flanges (except 5", which is fabricated – F37). Sizes larger than 24" are fabricated from heavy plate. The Figure C/F37 is available in all stainless steel (designated "S") or with alloy steel wetted parts and carbon steel external parts (designated "R"). In sizes 1.5" through 24", the "S" and the "R" share the same solid cast body. Sizes larger than 24" feature fabricated bodies configured to the service conditions. The Figure C/F37 is available with the widest range of seats in the industry including: integral metal, replaceable hardfaced metal, rubber "D" ring, replaceable rubber, polyurethane, UHMW-P, and PTFE. Standard body materials include 304, 316, and 317L stainless steel. Special alloys such as 254 SMO® are also available. Special flange drillings are also available.

All Figure C/F37 knife gate valves with handwheels include a provision for a locking device. Consult factory for details.

Specifications

Size Range

1.5" – 96"

Pressure Rating

1.5" – 24": 150 psi (10.3 bar) CWP (cold working pressure)
25" – 48": Designs available in 50 psi (3.5 bar), 100 psi (6.9 bar) or 150 psi (10.3 bar) CWP
Larger than 48": Manufactured to customer specification

Temperature Rating

1.5" – 48" 450°F (232°C).
Service temperatures above 400°F (204°C) require high temperature fasteners. Specify service temperature on paperwork. Consult factory for sizes larger than 48" (DN 1200) and for service temperatures up to 1500°F (816°C).

Flange Drilling

ANSI 125/150

Testing

Every Fabri-Valve Figure C/F37 valve is fully tested prior to shipment. Testing includes a body shell test, a seat test and a cycling test to insure proper functioning of moving parts. Additional testing is also available. Please let us know your requirements.

Standard Shell test:

- Hydro test at 1.5 times the rated CWP (cold working pressure) – Zero allowable leakage

Standard Seat test:

- Metal Seat: Hydro test at 40 psi (2.8 bar) and at the rated CWP
- Resilient Seat: Hydro test at 15 psi (1 bar) and rated CWP

Pressure/Temperature Ratings

The tables below are the Maximum Pressure/Temperature Ratings for the metallic components only. When checking pressure/temperature ratings, check the temperature rating and chemical compatibility of the packing material and, if applicable,

the resilient seat material. In a majority of knife gate valve designs, the temperature limit or the chemical compatibility of the seat and/or packing material determines the practical pressure/temperature limitations.

Figure C37								
Pressure/Temperature Rating - psi								
Temp		Cast 304	Cast 304L	Cast 316	Cast 316L	Cast 317L	Cast WCB A-216	Cast DI
°F	°C							
150	66	150	150	150	150	150	150	150
200	93	142	142	150	150	135	150	150
250	121	135	135	142	142	128	150	147
300	149	129	129	134	134	121	150	143
350	177	123	123	128	128	116	150	139
400	204	118	118	123	123	112	150	135
450	232	114	114	118	118	108	150	131
500	260	111	111	114	114	105	150	127
600	316	104	104	108	108	100	150	119
700	371	101	101	104	104	96	142	
800	427	96	96	100	100	92	103	
900	482	93		99			57	
1000	538	89		97			21	
1100	593	64		76				
1200	649	41		46				
1300	704	28		29				
1400	760	20		20				
1500	816	15		14				

Figure F37								
Pressure/Temperature Rating - psi								
Temp		304	304L	316	316L	317L	A 36	A516Gr70
°F	°C							
150	66	150	133	150	133	150	150	150
200	93	133	114	141	113	135	137	150
250	121	126	108	133	107	128	135	150
300	149	120	102	124	101	121	133	150
350	177	115	98	119	97	116	131	150
400	204	110	93	114	93	112	128	150
450	232	107	90	110	90	108	125	150
500	260	103	87	106	87	105	121	150
600	316	97	82	101	83	100	111	150
700	371	94	80	97	80	96	108	142
800*	427*	89	77	93	77	92		103
900*	482*	87		92				57
1000*	538*	83		90				21
1100*	593*	78		88				
1200*	649*	49		59				
1300*	704*	30		33				
1400*	760*	18		18				
1500*	816*	11		10				

Shutoff Performance

Metal Seat

- Single integral metal seat
 - 1.5" – 24" 40cc / minute / inch of valve size
 - 25" – 48" 60cc / minute / inch of valve size
 - Above 48" Consult Factory
- Single hardfaced integral metal seat
 - 1.5" – 24" 80cc / minute / inch of valve size
 - 25" – 48" 120cc / minute / inch of valve size
 - Above 48" Consult Factory
- Dual metal seats
 - Consult factory. All sizes.
- Single hardfaced replaceable metal seat
 - 1.5" – 24" 80cc / minute / inch of valve size
 - Above 24" Consult Factory

Resilient Seat

- Single "D" ring, or single replaceable resilient seat (excluding PTFE)
 - Zero leakage. All sizes.
- Dual seats
 - Consult Factory. All sizes.
- Single replaceable PTFE seat
 - Consult Factory. All sizes.

* "R" Series valves have external, non-wetted, carbon steel components. Standard "R" Series valves are limited to 700°F (371°C); however alternate "R" Series constructions are available to 1000°F (538°C)

NOTE: Each valve is identified by Size-Figure-Series-etc. The "How To Order" section explains the Valve Model Codes.

Low Pressure Operation

Metal seated knife gate valves are seat tested at 40 psid (2.8 bar) in the preferred flow direction. When pressure falls below the 40 psid (2.8 bar) test pressure, less force is pushing the gate into the seat, which may result in additional seat leakage. When improved low-pressure shutoff performance is required, optional chest buttons and/or centerline buttons should be specified.

Fabri-Valve® CF37 Heavy Duty Knife Gate Valve

Available Options

- "D" Ring Seat
- Lever Operator
- Dual Seats
- Poly Replaceable Seats
- UHMW Replaceable Seats
- PTFE Replaceable Seats
- Rubber Replaceable Seats
- Hard Faced Replaceable Seats
- Elastomer Replaceable Seats
- Hard Faced Gate Edge
- Hard Gate Material
- Nickel-TFE Coated Gate
- Epoxy Coating
- Thru Drilled Flanges
- Flush Ports
- Chest Buttons: Not available 2"-6"
- Centerline Buttons
- Backing Ring
- Extra Wedges
- V-Port
- Cast Ni-Hard Deflection Cones
Available 3"-16"
- Fabricated Deflection Cones
- Locking Devices
- Live Loaded Packing
- Self-Supporting Yokes
- Alternate Flange Drilling
- Bevel Gear
- Chainwheels
- Cylinder Actuators
- Electric Actuators
- Ratchet
- Extended Stems
- Gate Support Strips
- Rod Boots

Dimensions

Valve Size		TABLE 1 DIMENSION Inches (mm) Figure C37 with HANDWHEEL OR CYLINDER																	Weight **				
Inches	DN	A			C			D		H*	J	K	L	M	N	P	R	S	T	V	W	lb	kg
		HW	2-1/2 CYL	3-1/4 CYL	HW	2-1/2 CYL	3-1/4 CYL	2-1/2 CYL	3-1/4 CYL														
2	50	13-11/16 (348)	18-3/8 (467)	16-7/8 (429)	8 (203)	3 (76)	4 (102)	3/8-18	1/4-18	2 (51)	6 (152)	3/8 (10)	2	5/8-11NC	4	4-3/4 (121)	3-5/8 (92)	4 (102)	1/16 (2)	9/16 (14)	1-7/8 (48)	17	8
3	80	16-7/16 (418)	20-7/8 (530)	19-3/8 (492)	8 (203)	3 (76)	4 (102)	3/8-18	1/4-18	3 (76)	7-1/2 (191)	13/32 (10)	2	5/8-11NC	4	6 (152)	5 (127)	4 (102)	1/16 (2)	9/16 (14)	2 (51)	21	10
4	100	19-3/16 (487)	22-1/8 (562)	22-7/8 (581)	8 (203)	4 (76)	4-1/2 (114)	1/4-18	3/8-18	4 (102)	9 (229)	13/32 (10)	2	5/8-11NC	8	7-1/2 (191)	6-3/16 (157)	4 (102)	1/16 (2)	11/16 (17)	2 (51)	30	14
6	150	25-5/16 (643)	28-7/8 (733)	29-1/4 (743)	10 (254)	4-1/2 (114)	6-1/2 (165)	3/8-18	3/8-18	6 (152)	11 (279)	7/16 (11)	2	3/4-10NC	8	9-1/2 (241)	8-1/2 (216)	7-3/8 (187)	1/16 (2)	5/8 (16)	2-1/4 (57)	75	34
8	200	32-5/8 (829)	35-13/16 (910)	36-5/16 (922)	12 (305)	6-1/2 (165)	8-5/8 (219)	3/8-18	3/8-18	8 (203)	13-1/2 (343)	5/8 (16)	2	3/4-10NC	8	11-3/4 (298)	10-5/8 (270)	7-3/8 (187)	1/16 (2)	13/16 (21)	2-3/4 (70)	94	45
10	250	37-3/4 (959)	41-7/16 (1053)	42-3/16 (1072)	16 (406)	8-5/8 (219)	10-7/8 (276)	3/8-18	1/2-14	10 (254)	16 (406)	1/2 (13)	4	7/8-9NC	12	14-1/4 (362)	12-3/4 (324)	7-3/8 (187)	1/8 (3)	15/16 (24)	2-3/4 (70)	126	57
12	300	44-9/16 (1132)	48 (1219)	48-3/4 (1238)	16 (406)	8-5/8 (219)	10-7/8 (276)	3/8-18	1/2-14	12 (305)	19 (483)	1/2 (13)	4	7/8-9NC	12	17 (432)	15 (381)	7-1/2 (191)	3/16 (5)	1 (25)	3 (76)	177	80
14	350	49-1/4 (1251)	54-1/16 (1373)	55-3/16 (1402)	20 (508)	12-3/4 (324)	14-3/4 (375)	1/2-14	3/4-14	13-1/4 (337)	21 (533)	7/16 (11)	4	1-8NC	12	18-3/4 (476)	16-1/4 (413)	7-3/4 (197)	3/16 (5)	15/16 (24)	3 (76)	215	98
16	400	56-1/2 (1435)	61-1/16 (1551)	62-3/16 (1580)	20 (508)	12-3/4 (324)	14-3/4 (375)	1/2-14	3/4-14	15-1/4 (387)	23-1/2 (597)	9/16 (14)	6	1-8NC	16	21-1/4 (540)	18-1/2 (470)	11-1/4 (286)	3/16 (5)	1-1/16 (27)	3-1/2 (89)	268	122
18	450	63-5/16 (1608)	66-1/2 (1689)	67-5/8 (1718)	20 (508)	12-3/4 (324)	14-3/4 (375)	1/2-14	3/4-14	17-1/4 (438)	25 (635)	5/8 (16)	6	1-1/8-7NC	16	22-3/4 (578)	21 (533)	11-1/4 (286)	3/16 (5)	1-1/16 (27)	3-1/2 (89)	407	185
20	500	68-5/8 (1743)	72-15/16 (1853)	73-7/16 (1865)	20 (508)	14-3/4 (375)	17 (432)	3/4-14	3/4-14	19-1/4 (489)	27-1/2 (699)	29/32 (23)	8	1-1/8-7NC	20	25 (635)	23 (584)	14 (356)	3/16 (5)	1-3/16 (30)	4-1/2 (114)	523	237
24	600	79-13/16 (2027)	84-11/16 (2151)	86-5/8 (2200)	20 (508)	17 (432)	19 (483)	3/4-14	3/4-14	23-1/4 (591)	32 (813)	13/16 (21)	8	1-1/4-7NC	20	29-1/2 (749)	27-1/4 (692)	14-1/8 (359)	3/16 (5)	1-5/16 (33)	4-1/2 (114)	713	321

Reference dimensions in (parentheses)

* For 14" - 24" valves with rubber replaceable seats, use the port I.D. dimensions show in the Flow Coefficients Table (see last page).

** Figures C37R and C37S with Handwheels

Refer to TABLE 1 for dimensions

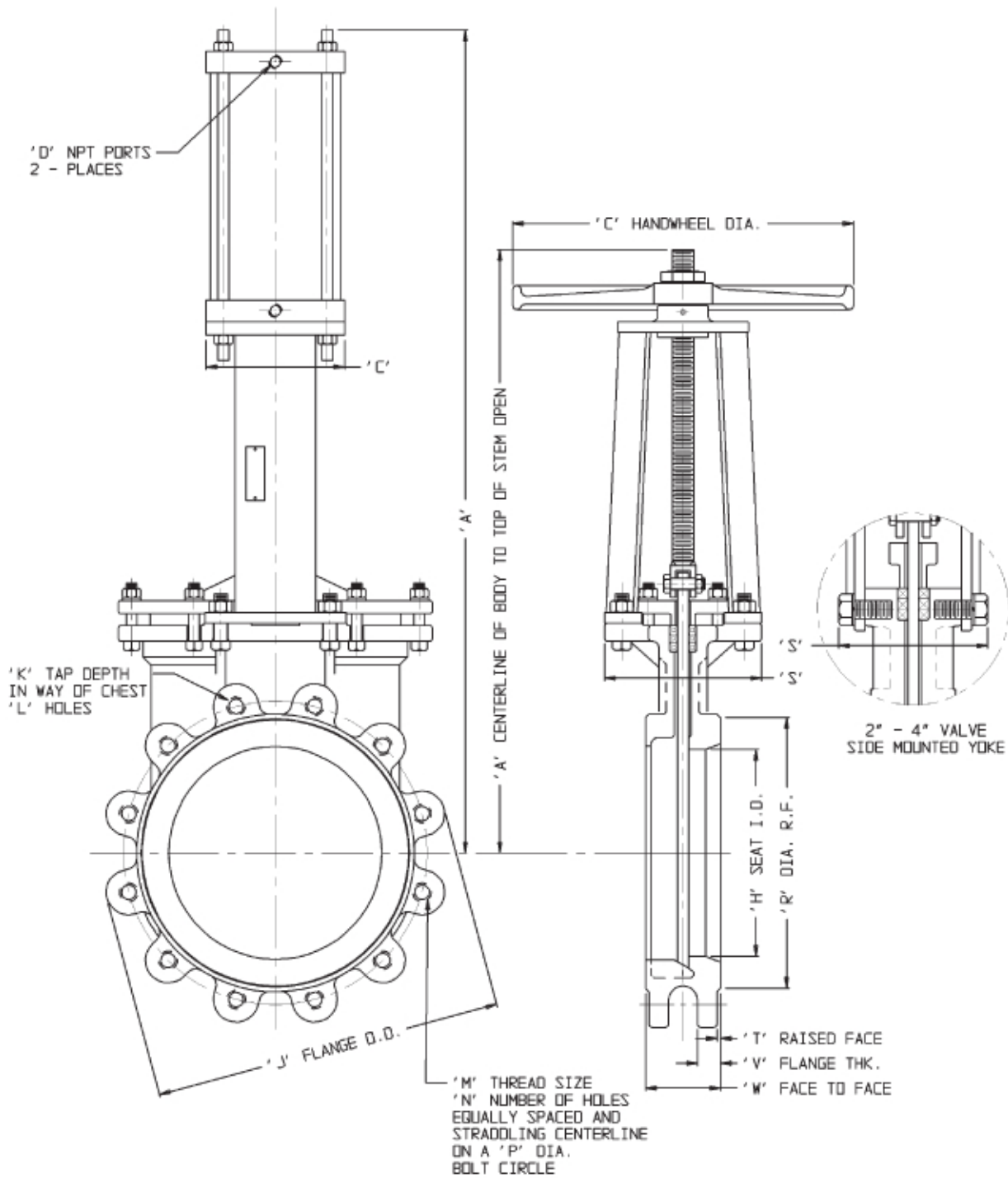

with Cylinder

with Handwheel

Fabri-Valve® CF37 Heavy Duty Knife Gate Valve

Dimensions

		Valve Size TABLE 2										DIMENSION Inches (mm) Figure C37 with BEVEL GEAR							
Inches	DN	A	B	C	D	E	H	J	K	L	M	N	P	R	S	T	V	W	
6	150	25-5/16 (643)	19-11/16 (500)	12 (305)	12-3/8 (314)	6-1/2 (165)	6 (152)	11 (279)	7/16 (11)	2	3/4-10NC	8	9-1/2 (241)	8-1/2 (216)	7-3/8 (187)	1/16 (2)	5/8 (16)	2-1/4 (57)	
8	200	32-15/16 (837)	24-5/8 (625)	12 (305)	12-3/8 (314)	6-1/2 (165)	8 (203)	13-1/2 (343)	5/8 (16)	2	3/4-10NC	8	11-3/4 (298)	10-5/8 (270)	7-3/8 (187)	1/16 (2)	13/16 (21)	2-3/4 (70)	
10	250	38-1/16 (967)	27-9/16 (700)	12 (305)	12-3/8 (314)	6-1/2 (165)	10 (254)	16 (406)	1/2 (13)	4	7/8-9NC	12	14-1/4 (362)	12-3/4 (324)	7-3/8 (187)	1/8 (3)	15/16 (24)	2-3/4 (70)	
12	300	44-9/16 (1132)	31-13/16 (808)	12 (305)	12-3/8 (314)	6-1/2 (165)	12 (305)	19 (483)	1/2 (13)	4	7/8-9NC	12	17 (432)	15 (381)	7-1/2 (191)	3/16 (5)	1 (25)	3 (76)	
14	350	49-5/16 (1252)	34-3/4 (883)	12 (305)	12-3/8 (314)	6-1/2 (165)	13-1/4 (337)	21 (533)	7/16 (11)	4	1-8NC	12	18-3/4 (476)	16-1/4 (413)	7-3/4 (197)	3/16 (5)	15/16 (24)	3 (76)	
16	400	56-9/16 (1437)	40-3/8 (1026)	12 (305)	12-1/16 (306)	6-1/2 (165)	15-1/4 (387)	23-1/2 (597)	9/16 (14)	6	1-8NC	16	21-1/4 (540)	18-1/2 (470)	11-1/4 (286)	3/16 (5)	1-1/16 (27)	3-1/2 (89)	
18	450	63-5/16 (1608)	43-13/16 (1113)	12 (305)	12-1/16 (306)	6-1/2 (165)	17-1/4 (438)	25 (635)	5/8 (15)	6	1-1/8-7NC	16	22-3/4 (578)	21 (533)	11-1/4 (286)	3/16 (5)	1-1/16 (27)	3-1/2 (89)	
20	500	68-5/8 (1543)	47-15/16 (1218)	12 (305)	12-1/16 (306)	6-1/2 (165)	19-1/4 (489)	27-1/2 (699)	29/32 (23)	8	1-1/8-7NC	20	25 (635)	23 (584)	14 (356)	3/16 (5)	1-3/16 (30)	4-1/2 (114)	
24	600	79-7/8 (2029)	55-3/16 (1402)	12 (305)	12-1/16 (306)	6-1/2 (165)	23-1/4 (591)	32 (813)	13/16 (21)	8	1-1/4-7NC	20	29-1/2 (749)	27-1/4 (692)	14-1/8 (359)	3/16 (5)	1-5/16 (33)	4-1/2 (114)	

Reference dimensions in (parentheses)
 6" - 14" valves have a bevel gear ratio of 3:1
 16" - 24" valves have a bevel gear ratio of 4:1

Materials of Construction

Part	Materials	
	C37R & F37R	C37S & F37S
Body and Chest	1.5" - 24" (except 5") solid one piece. C37R-304: Cast 304 stainless steel C37R-316: Cast 316 stainless steel C37R-317L: Cast 317L stainless steel Larger than 24" and the 5" are fabricated with stainless steel wetted parts and carbon steel exterior parts.	1.5" - 24" (except 5") solid one piece. C37S-304: Cast 304 stainless steel C37S-316: Cast 316 stainless steel C37S-317L: Cast 317L stainless steel Larger than 24" and the 5" are fabricated of all stainless steel
Seat	Integral seat to 1500°F (816°C) with appropriate packing RH: Replaceable hardfaced seat to 750°F (399°C) standard Up to 1600°F (871°C) with proper packing and gaskets RT: Replaceable PTFE seat to 400°F (204°C) RW: Replaceable UHMWPE seat to 140°F (60°C) RP: Replaceable polyurethane seat to 180°F (82°C)	
Gate	Stainless steel of same grade used in body, finished to 32 RMS	
Yoke	1.5" - 4", Cast ductile iron 6" and above fabricated carbon steel	1.5" - 4", cast 304 stainless steel 6" and above fabricated 304 stainless steel
Yoke Fasteners	Plated steel	Stainless steel
Stem	304 stainless steel	
Stem Nut	Acid resistant bronze	
Lubrication Fitting	Plated steel	
Packing	Acrylic/PTFE/silicone ¹	
Packing Follower	Ductile iron/carbon steel with plated steel bolts	304 stainless steel with stainless steel bolts
Handwheel	Cast iron	
Handwheel Retaining Nut	Malleable iron	Stainless steel
Tab Washer	Stainless steel	

¹ Energized cored packing is standard with 6" (DN150) and larger C37 valves and all F37 valves.

Refer to TABLE 2 for dimensions

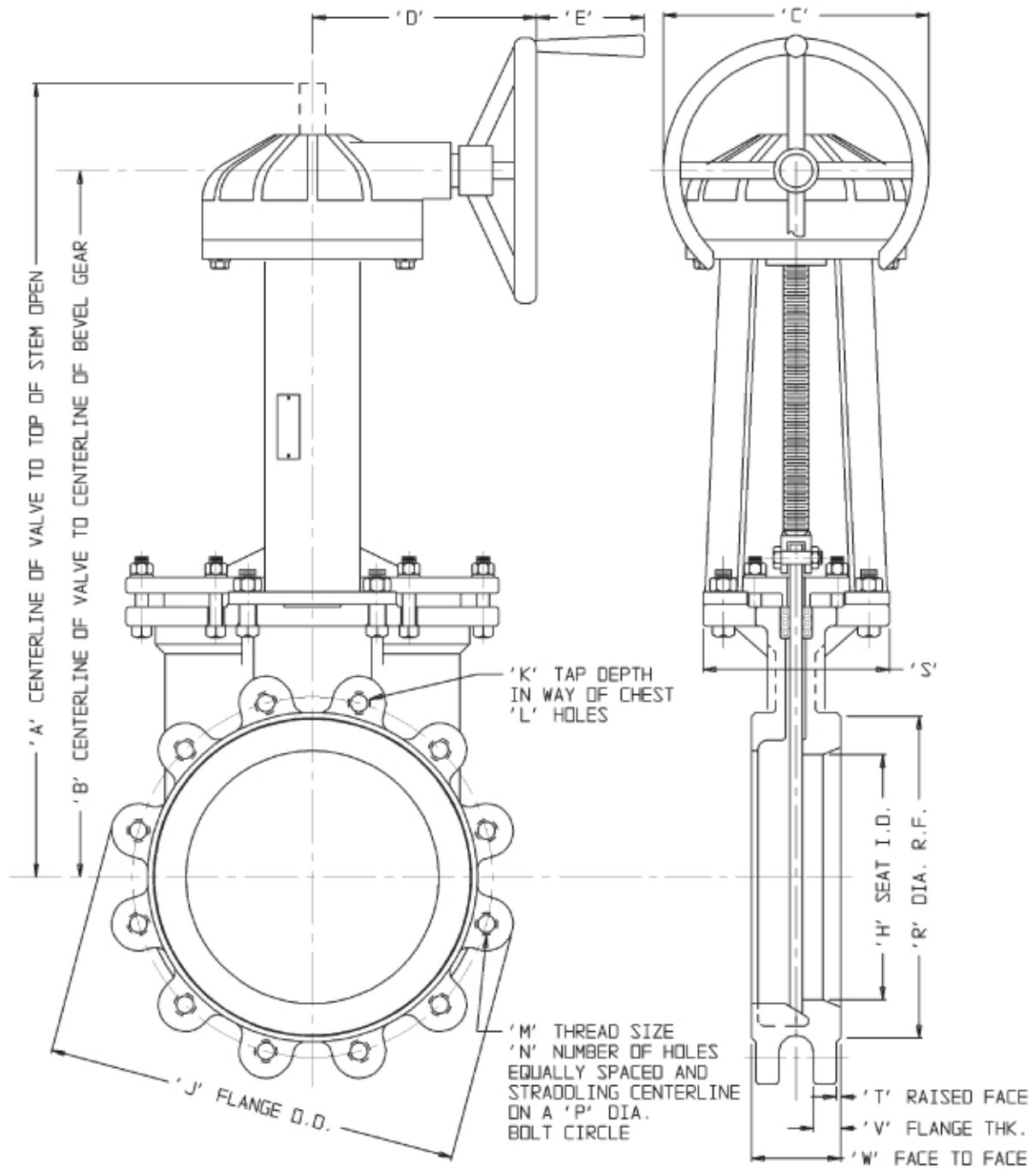

Flow Coefficients

The Cv values below represent U.S. gallons per minute 60°F water through a 100% open valve at a pressure drop of 1 psi. The metric equivalent, Kv, is the flow of water at +16°C through the valve in cubic meters per hour at a pressure drop of 1 kg/cm². To convert Cv to Kv, multiply the Cv by 0.8569.

Figures C37 and F37 Cv Ratings, Port Diameter, and Area										
Valve Size In. DN		Standard Port			With V-Seat			With Replaceable Poly or Replaceable Rubber seat		
		Cv	Port I.D. Inches	Port Area Sq. In.	Cv	Port Inside Inches	Port Area Sq. In.	Cv	Port I.D. Inches	Port Area Sq. In.
2	50	288	2.00	3.1	165	2.00	2.8	288	2.00	3.1
3	75	648	3.00	7.1	355	3.00	6.3	648	3.00	7.1
4	100	1,152	4.00	12.6	515	4.00	9.5	1,152	4.00	12.6
6	150	2,592	6.00	28.3	1,350	6.00	24.9	2,592	6.00	28.3
8	200	4,608	8.00	50.3	2,050	8.00	38.1	4,608	8.00	50.3
10	250	7,208	10.00	78.5	3,200	10.00	59.0	7,208	10.00	78.5
12	300	10,400	12.00	113.1	4,450	12.00	82.3	10,400	12.00	113.1
14	350	12,650	13.25	137.9	5,350	13.25	98.8	10,080	12.00	113.1
16	400	16,750	15.25	182.6	6,950	15.25	128.4	14,200	14.25	159.5
18	450	21,450	17.25	233.7	10,700	17.25	198.2	18,500	16.25	207.4
20	500	26,700	19.25	291.0	13,250	19.25	245.4	22,700	18.00	254.5
24	600	38,900	23.25	424.6	15,400	23.25	284.7	33,900	22.00	380.1
30*	750*	49,850	26.69	559.4						
36*	900*	74,800	32.69	839.2						
42*	1050*	104,800	38.69	1175.5						
48*	1200*	136,700	44.19	1533.5						

Consult Factory

*50 psi (3.5 bar) CWP valve design. Contact factory for higher pressure designs.

Engineered Valves

For more information contact:

Engineered Valves

1110 Bankhead Avenue

Amory, MS 38821 USA

Phone: (800) 541-1849

(662) 256-7185

Fax: (662) 256-7932

Web site: www.engvalves.com

E-mail: engvalves.custserv@itt.com



Engineered for life

© 2007 ITT Corporation