

INSTALLATION AND MAINTENANCE INSTRUCTIONS
Figure XS150 - ULV (Urethane Lined Valve)
FABRI-VALVE® BI-DIRECTIONAL HIGH PERFORMANCE KNIFE GATE VALVE



TABLE OF CONTENTS

0.0 GENERAL	2
1.0 INSTALLATION	3
2.0 OPERATION AND ADJUSTMENT	6
3.0 MAINTENANCE	6
3.1 Periodic Inspection.....	6
3.2 General	7
3.3 Lifting	8
3.4 Packing Adjustment	9
3.5 Lubrication (Stem & Stem nut)	10
3.6 Electric Actuators	10
3.7 Seal Replacement.....	10
3.8 Setting of Valve Stroke.....	11
3.9 Transport and Storage	11
4. SERVICE / SPARE PARTS	12
4.1 Recommended Mating Flange Fasteners	12
5. EXPLODED VIEW	13

0.0 GENERAL

The latest edition of this manual can be found on the website listed on page 1 or the back page.

0.1 Safety

	The safety precautions in these operating instructions are specially marked with the standard symbol for danger when non-observance could result in personal injury, loss of life or property damage.
	Non-observance of these safety precautions can endanger the valve and its functions.

0.1.1 Qualifications and training of personnel

The personnel responsible for operation, maintenance, inspection and assembly must be appropriately qualified.

The operating company must precisely define the responsibilities, competence and supervision of the personnel. If the personnel lack the necessary knowledge, they are to be trained and instructed. If required this can be carried out by the manufacturer/supplier of the valve by order of the operating company. Furthermore, the operating company is to ensure that the contents of the operating instructions have been fully understood by the personnel.

0.1.2 Dangers through non-observance of the safety precautions

Failure to observe all of the safety precautions can result in the endangering of lives as well as the environment and the valve. The non-observance of the safety precautions can lead to the loss of all claims for damages.

0.1.3 Safety precautions for the operating company/individual operator

- If hot or cold components of the valves are a source of danger, these components must be secured against contact by operating company.
- Contact guard for moving parts may not be removed when valve is in operation.
- Do not hang items off the valves. Any accessories must be firmly or permanently attached.
- Do not use the product as a step or hand hold.

0.1.4 Safety precautions for maintenance, inspection and assembly

Work on externally actuated valves should only be carried out when the valve is removed from service.

On completion of work, all safety and protective equipment must immediately be fitted again or reactivated.

0.1.5 Unauthorized reconstruction and manufacture of spare parts

Reconstruction or modification of the valve or any component is only permissible after consulting the manufacturer. Genuine spare parts and accessories authorized by the manufacturer serve to maintain safety. The use of other parts can annul all liability for the consequences.

0.1.6 Inadmissible modes of operation

The operating limits given on the identification tag and in the data sheet may not be exceeded under any circumstances.

If the product label or identification tag is missing or worn contact manufacturer at the address listed on page 1 or the back page for specific instructions.

1.0 INSTALLATION

	The XS150ULV was designed for use with metal mating flanges meeting ANSI B16.1, either flat faced or raised face.
---	---

	Fiberglass flanges: Consult with the Fiberglass Flange manufacturer to determine if support rings are required for use with raised-faced flanges.
---	--

	Rubber lined pipe with rubber lined mating flanges: Load distribution rings are required for raised face valves if installed in this application. Consult factory for details.
---	--

	Any flange or pipeline welding should be done prior to installation of the valves. Valve liner and seat can be damaged by excessive heat.
---	---

	The XS150-ULV is NOT suitable for “Dead-End” service. Installation at the end of a pipeline requires the use of a blind or “donut” flange. Failure to do so will damage the valve liner and seat.
---	--

	Valves supplied with spring to close cylinders are shipped with a gate stop bracket. This bracket must be removed after installation of valve between 2 mating flanges. If bracket is removed prior to installation damage to liners and seal may occur.
---	---

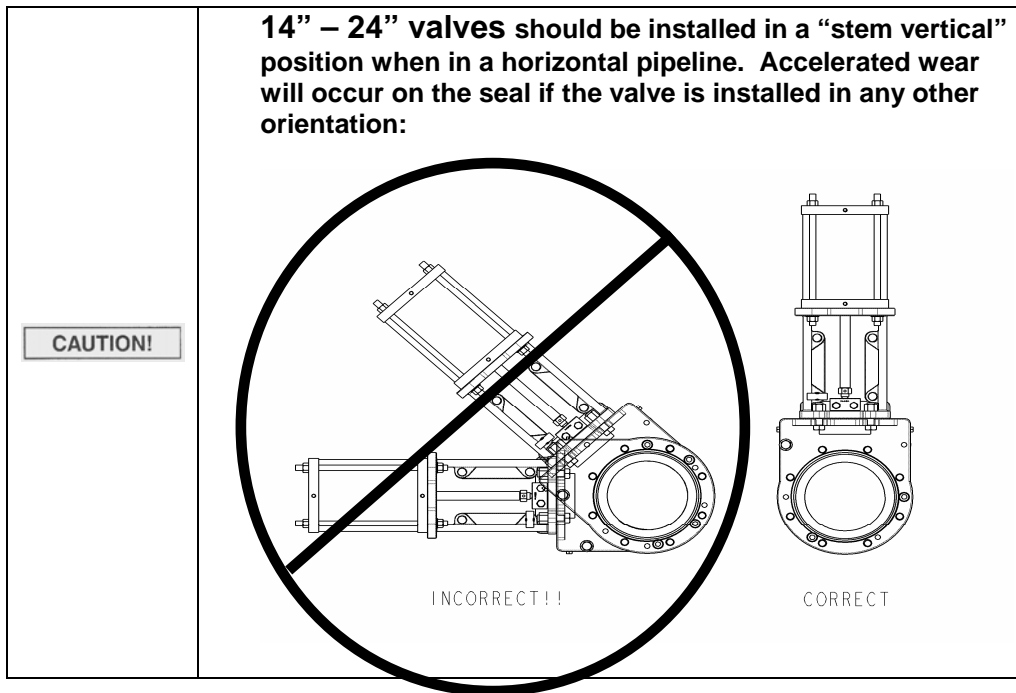

Fabri-Valve XS150 ULV Recommended Flange Gaskets

Note: The XS150 includes an integrated O-ring seal. Flange Gaskets are not required. In some cases a gasket may be used if the o-ring is damaged or missing.

Mating Pipe Flanges	Standard Flat Face VALVE Flanges		Optional Raised Face VALVE Flanges	
	Standard Installation	NON-Standard Installation	Standard Installation	NON-Standard Installation
	NO Flange Gaskets	Compressible Gasket with each mating flange	NO Flange Gaskets	Compressible Gasket with each mating flange
Standard Metal Raised Faced Pipe Flanges	OK	Not Recommended (1)	OK	Not Recommended (1)
Metal Flat Face pipe flanges	OK	OK only with full face gasket	OK	Not Recommended (1)
Rubber-lined pipe and end flange	OK	OK only with full face gasket	Not Recommended (1)	Not Recommended (1)
Fiberglass or Plastic Flat-Faced pipe flanges	OK	OK only with full face gasket	Not Recommended	Not Recommended

(1) OK with Load Distribution Ring

CAUTION!	The use of flange gaskets may affect valve performance and shorten the life of the valve liner.
-----------------	--

1.1 Check to ensure that the o-ring face seal on each face of the valve is in place and undamaged.

- 1.2 The valve should be tightened between flanges using appropriate fasteners for the service, in compliance with applicable piping codes and standards.
- 1.3 Bolt the valve to the mating flange using proper size bolts and/or studs. If stainless bolts or studs are used, lubricate threads to prevent galling.

Recommended fasteners are listed in Section 4.1

- 1.4 When tightening flange bolts, work from side to side in an alternating sequence to ensure even compression of the O-ring or gasket. See Figure 1

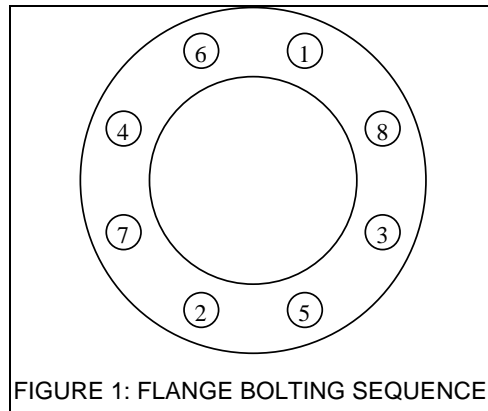

- 1.5 If there is seepage past the chest seal upon installation, the valve may have been subject to wide temperature variations during shipment. Leak tight performance can be restored by the simple packing adjustment procedure in the Maintenance Section 3-4.
NOTE: All valves are pressure and seat tested before shipment.
- 1.6 If the valve is installed in horizontal position and an actuator is included with the valve, support of the actuator may be required. Consult the factory for technical advice.
- 1.7 Air operated valves must be supplied with clean, dry, regulated air.



WARNING: MATING PIPE FLANGES SHOULD BE TIGHT AGAINST THE VALVE FLANGES TO PROPERLY ENERGIZE THE O-RING FLANGE SEAL. PROCESS PRESSURE SHOULD BE BROUGHT UP SLOWLY TO CHECK FOR LEAKS BETWEEN THE VALVE AND PIPE FLANGES. SERIOUS INJURY OR DEATH COULD RESULT FROM MEDIA LEAKAGE BETWEEN THE PIPE FLANGES AND THE VALVE.



WARNING: VALVES THAT ARE SUPPLIED WITH CYLINDERS ARE SIZED FOR A SPECIFIED PRESSURE. EXCESSIVE PRESSURE COULD RESULT IN SERIOUS PERSONAL INJURY OR MAY CAUSE DAMAGE TO THE VALVE AND/OR CYLINDER. AIR REGULATORS AND AIR FILTERS ARE AVAILABLE FROM YOUR ITT DISTRIBUTOR.



2.0 OPERATION AND ADJUSTMENT

2.1 All valves are pressure and seat tested before shipment and an inspection tag is attached.

The Packing may require some adjusting after line pressure is up to normal. Tighten the packing bolts just enough to stop leakage. All four packing screws must be adjusted equally to maximize the life of the valve. Over tightening may cause binding and/or rapid wear.

3.0 MAINTENANCE

ALL MAINTENANCE PROCEDURES MUST BE PERFORMED BY QUALIFIED PERSONNEL. MAINTENANCE DONE BY PERSONNEL NOT QUALIFIED TO PERFORM IT COULD RESULT IN PERSONAL INJURY, DEATH OR PROPERTY DAMAGE.

CAUTION!	The “closed position” stop is set at the factory to provide tight shutoff. DO NOT OVERRIDE. “Over-closing” the valve may cause the gate to over-compress the seat and damage the seat.
	NEVER USE UNAPPROVED MEANS OF ACTUATING THE VALVE. THE USE OF A “CHEATER BAR” TO OPERATE MANUALLY OPERATED VALVES COULD LEAD TO SERIOUS INJURY AND PROPERTY DAMAGE.
	REMOVE ALL LINE PRESSURE BEFORE SERVICING VALVE.
	REMOVE ELECTRICAL, PNEUMATIC OR HYDRAULIC POWER TO THE VALVE ACTUATOR BEFORE PERFORMING ANY MAINTENANCE.

3.1 Periodic inspection

	WHEN THE PROCESS FLUID IS HAZARDOUS OR CORROSIVE, EXTRA PRECAUTIONS SHOULD BE TAKEN. THE USER SHOULD EMPLOY APPROPRIATE SAFETY DEVICES AND SHOULD BE PREPARED TO CONTROL A LEAK OF THE PROCESS FLUID. FAILURE TO FOLLOW THESE INSTRUCTIONS COULD RESULT IN SERIOUS PERSONAL INJURY OR DEATH, AND PROPERTY DAMAGE.
---	--

Periodically inspect condition of external valve parts. Replace all parts showing excessive wear or corrosion. Contact manufacturer at the address listed on page 1 or the back page in order to obtain replacement parts or for specific instructions.

3.2 General

- 3.2.1 Maintenance on the XS150-ULV is a straightforward procedure. To assist in the proper assembly of the valve after maintenance, it is recommended that the user NOT make adjustments to the stem clamp (on actuated valves) or the upper stop collar (on manually operated valves.) This will help insure that the valve stroke is correctly set upon re-assembly.
- 3.2.2 The rubber seal should be replaced whenever the urethane liners are replaced to insure optimal performance of the valve.
- 3.2.3 An appropriate lubricant should be applied to the gate and seal if the valve is going to be cycled dry. Dry cycling the valve will lead to premature seal wear and could affect smooth operation of the valve.
- 3.2.4. Never remove the yoke or actuator while the valve is installed in a pipeline.



3.3 Lifting - General

 **DO NOT LIFT VALVES BY THE HAND WHEEL**

 **USE LIFTING EQUIPMENT RATED FOR THE WEIGHT OF THE VALVE ASSEMBLY**

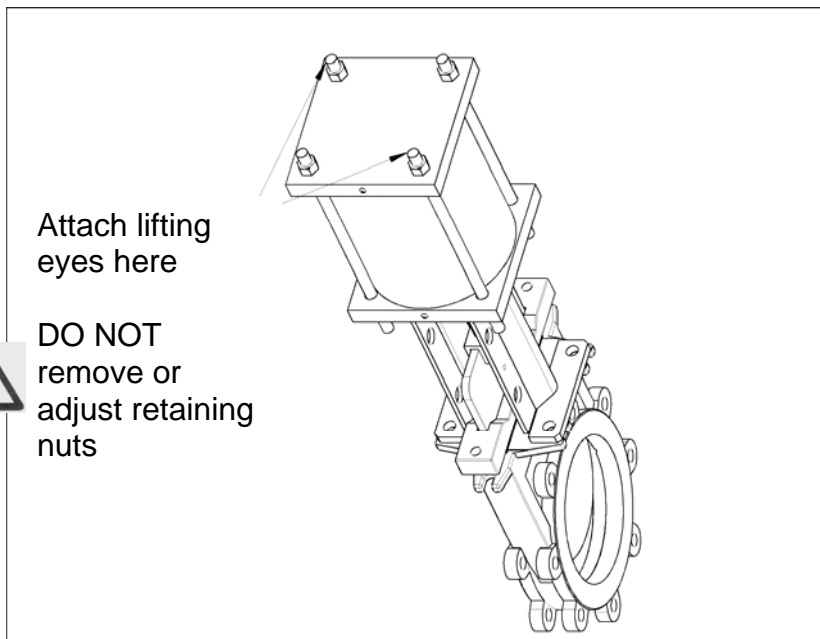
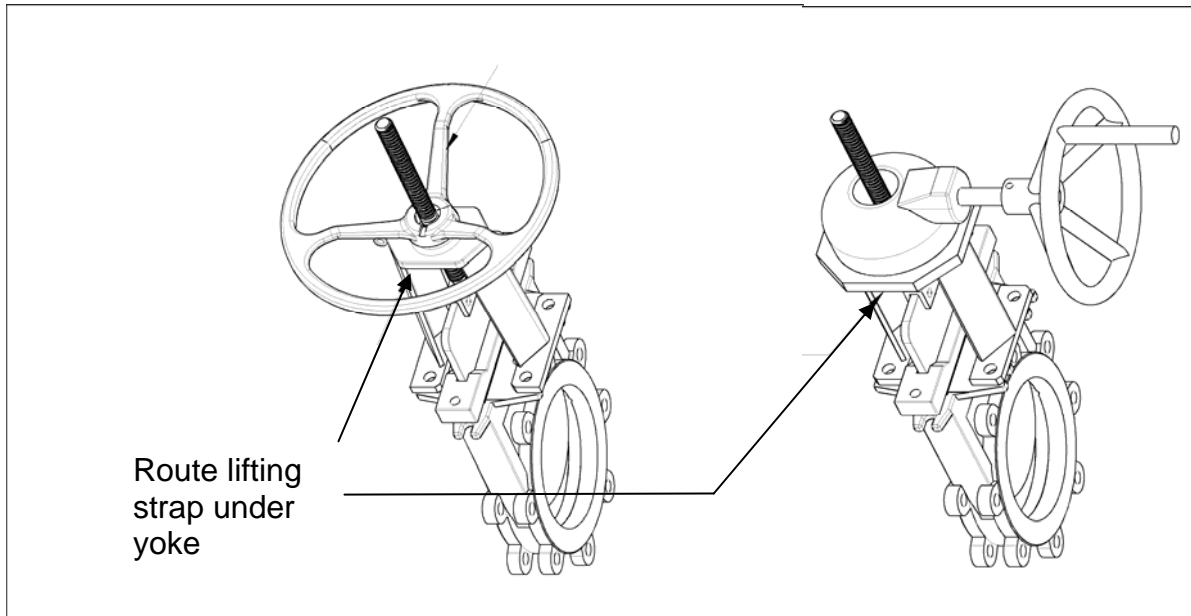

3.4 PACKING ADJUSTMENT (Injectable)

	SPECIAL PRECAUTIONS MUST BE TAKEN BEFORE REMOVING THE PACKING BOLTS. WEAR PROTECTIVE CLOTHING AND EQUIPMENT NORMALLY REQUIRED TO AVOID INJURY FROM THE PARTICULAR FLUID IN THE LINE. WEAR PROTECTIVE CLOTHING AND PROTECTIVE EQUIPMENT THAT SAFEGUARDS EYES, FACE, HANDS, ALL SKIN AND LUNGS. IF THERE IS ANY DOUBT, CONTACT THE PROPER SUPERVISOR IMMEDIATELY.
---	--

- 3.4.1 The packing adjustments to the XS150-ULV can be made while the valve is under working pressure. Read the entire warning below.
- 3.4.2 Occasionally, the XS150-ULV's chest seal may require an adjustment. To adjust the XS150-ULV's chest seal, inject small amounts of the packing material through each of the injection holes until the leak stops. Inject just enough packing to stop leakage. Over packing the chest seal may cause undue pressure against the gate making the valve difficult to operate and cause rapid chest seal wear. If possible, stroke the valve a few times before injecting packing. **IMPORTANT:** Packing must be added evenly to all four ports to evenly load the chest seal.
- 3.4.3 Determine the location of the leak and slowly tighten the nearest packing injection bolt. If this bolt is already bottomed out, new packing will have to be injected into the seal cavity. Slowly remove the packing injection bolt that is closest to the leak. Read the entire warning below.

	REMOVE THE PACKING SCREWS VERY SLOWLY AND WATCH FOR ANY SIGNS INDICATING LEAKAGE PAST THE PACKING BOLT. IF ANY LEAKAGE PAST THE PACKING BOLT IS OBSERVED WHEN THE BOLT IS BEING REMOVED, QUICKLY SCREW THE BOLT BACK TO ITS FULL DEPTH. THE PIPELINE WILL NEED TO BE DE-PRESSURIZED BEFORE THE VALVE'S CHEST SEAL CAN BE REPACKED.
---	---

- 3.4.4 Inject small amounts of packing by placing it in the hole and slowly pushing it into the valve.

NOTE: A simple re-packing tool will be required for packing the valve. This packing tool can easily be fabricated on the job site. Use a piece of rod or a round shank screw driver with the end cut off or a 3/16" Allen wrench to force the packing into the lateral seal. (The tool diameter should be approximately 0.21") The shank length of the tool should be at least 5" long. If you make the tool yourself, grind a small chamfer on the end of the tool to prevent damaging the threads in the injection holes.

- 3.4.5 Replace the packing injection bolt and tighten until snug. Inspect for leaks. If leaks continue, repeat step 3.4.4 until the leak stops. Care should be taken not to over fill the lateral seal with packing as this could lead to premature failure due to wear against the gate.

3.5 LUBRICATION (STEM & STEMNUT)

The stem and stemnut are lubricated at the factory before shipment. However, these parts should be lubricated periodically to prevent wear and to minimize operating forces. Some recommended lubricants are:

- CHEVRON INDUSTRIAL GREASE-MEDIUM
- TEXACO MOLYTEX GREASE #2
- MOLY XL 47-F2-75
- FEL-PRO C5-A COMPOUND

3.6 VALVES WITH ELECTRIC ACTUATORS

Valves with electric motors should be set up as positioned limit closed.

3.7 SEAL REPLACEMENT

1. Valve must be completely disassembled to remove and replace the valve seal.
2. Clean the gate and smooth any marred or rough surfaces by using a scotch-brite pad. It should be free of grooves and scratches. Set the gate aside until re-assembly.
3. Reassemble the valve as shown on Page 13.
4. Repack the valve by using the packing replacement procedure (See Section 3.4).
5. Replace the two o-ring seals on the flange faces by using a bonding agent such as loctite 380. Apply a small amount of glue in the groove to hold the o-ring in place during valve installation. Mating flanges should be metal raised face or flat faced.
6. On handwheel actuated valves, reconnect the non-rising stemnut back to the gate by using the non-rising stemnut fasteners. There is no stroke adjustment necessary for handwheel actuated valves. Proceed to step 26.
7. On cylinder actuated valves, insert the gate clamp bolt(s) through the gate clamp to secure the gate into place. Adjust the stroke per Section 3.7, then continue at step 26.
8. On bevel gear actuated valves, reconnect the gate clamp back to the gate by using the gate clamp fasteners. Adjust the stroke per Section 3.7, then continue at step 26.
9. Adjust the packing for tight shutoff when the valve is installed and pressurized to operating pressure. See Section 3.3.
10. Maintenance manuals for cylinders, electric motors, and other accessories are available from the factory.

3.8 SETTING VALVE STROKE

CAUTION!	FAILURE TO ADJUST CLOSED POSITION PROPERLY MAY CAUSE LEAKAGE, DAMAGE, OR PREMATURE FAILURE OF SEAL.
-----------------	--

On bevel gear actuated valves, adjust the top stroke limiter to allow compression of the seal at the bottom of the port as follows: lower the gate until the lockout pin just clears the top of the gate while in the lower lock-out hole. This is the proper closed position.

On cylinder actuated valves, close the valve and inspect the seal compression at the bottom of the port. This compression should be the same as on bevel gear actuated valves. Adjustments to seal compression can be made by either screwing the gate clamp in or out of the cylinder rod. When the compression is set, install the gate clamp nut(s) on bolt(s) and tighten. Then tighten jam nut against cylinder rod.

3.9 TRANSPORT AND STORAGE

3.9.1 Transport

The goods have to be carefully handled in order to prevent damage. Valves to be handled with care to prevent damage during shipping. Valves are to be lifted from pallets only as specified in section 3.3

The end flange caps supplied are to be fitted to the valve as applicable.

3.9.3 Storage

If the valve is not to be installed immediately following delivery, it must be properly stored.

If the valve is to be stored for an extended period of time before installation, the valve should be stored in accordance with ITT's Long Term Storage Procedure. Contact the manufacturer using the information on page 1 to obtain this procedure.

In general, the valve should be stored in a vertical position and in a cool, clean area to prevent damaging effects on the chest and gate seal.

Storage should be in a dry temperature controlled environment. Product should not be stacked on top of one another.

3.9.4 Disposal, Recycle or Return shipment

The personnel responsible for disposal of the product or associated components are to comply with federal, state and local requirements.

If the return shipment is required, contact manufacturer at the address listed on page 1 for specific instructions.

Valves must be cleaned of all hazardous material before any maintenance is performed or valve is returned to manufacturer. An MSDS is required for all materials used in valve before it can be returned to the manufacturer.

4.0 SERVICE / SPARE PARTS

Size		Seal Material One Piece Perimeter & Chest Seal			Packing	Liner
Inches	DN	Aflas	Viton	EPDM		Urethane
2	50	155512	155524	155500	137375	159800
3	80	155513	155525	155501	"	159801
4	100	155514	155526	155502	"	159802
6	150	155515	155527	155503	"	159803
8	200	155516	155528	155504	"	159804
10	250	155517	155529	155505	"	159805
12	300	155518	155530	155506	"	159806
14	350	155519	155531	155507	"	
16	400	155520	155532	155508	"	
18	450	155521	155533	155509	"	
20	500	155522	155534	155510	"	
24	600	155523	155535	155511	"	

4.1 Recommended Mating Flange Fasteners

CAUTION!	<p>The bolt and stud lengths below assume that the mating flange thickness meets ANSI B16.5 for flat-faced, class-150 flanges. If raised face flanges, load distribution rings, or support rings utilized, the fastener lengths MUST be adjusted to maintain the desired thread engagement. Increase or decrease fastener lengths as necessary to ensure proper thread engagement.</p>
-----------------	--

CAUTION!	<p>Damage to the valve body may occur if a flange bolt is "bottomed out" in a tapped hole. Use of studs is highly recommended in tapped holes.</p>
-----------------	---

Size		Fastener Diameter & Thread	Total No. of Fasteners	No. Tapped Holes in Valve Chest	Stud Bolt Length (min)	Machine Bolt Length (min)
Inches	DN					
2*	50	5/8-11 UNC	8	4	3.25"	1.50"
3*	80	5/8-11 UNC	8	4	3.75"	1.50"
4*	100	5/8-11 UNC	16	4	3.75"	1.50"
6	150	3/4-10 UNC	16	4	2.75"	1.50"
8	200	3/4-10 UNC	16	4	4.25"	2.00"
10	250	7/8-9 UNC	24	8	4.75"	2.00"
12	300	7/8-9 UNC	24	8	4.75"	2.25"
14	350	1-8 UNC	24	8	5.25"	2.50"
16	400	1-8 UNC	32	12	5.50"	2.50"
18	450	1-1/8-7 UNC	32	12	6.00"	2.75"
20	500	1-1/8-7 UNC	40	16	6.25"	2.75"
24	600	1-1/4-7 UNC	40	16	7.00"	3.00"

* denotes flat face flange style

5. EXPLODED VIEW

PARTS LIST			
ITEM	DESCRIPTION	MATERIAL	
		R' SERIES	S' SERIES
1	O-RING		NITRILE
2	BODY HALF		CARBON STEEL
3	LINER		URETHANE
4	SEAL		EPDM, VITON, AFLAS
5	SOCKET HEAD CLAMPING BOLT		STAINLESS STEEL
6	CAPSCREW CLAMPING BOLT		STAINLESS STEEL
7	CLAMP BOLT WASHER		STAINLESS STEEL
8	YOKE TO BODY BOLT	PLATED STEEL	STAINLESS STEEL
9	INJECTION PORT BOLT		STAINLESS STEEL
10	YOKE HALF	CARBON STEEL	304SS
11	YOKE RETAINER NUT	CARBON STEEL	STAINLESS STEEL
12	GATE		SS AS SPECIFIED BY CUSTOMER
13	SERIAL NUMBER TAG		STAINLESS STEEL
14	NON RISING STEM NUT		ACID RESISTANT BRONZE
15	STEM NUT BOLTS	PLATED STEEL	STAINLESS STEEL
16	TRAVEL STOP		STAINLESS STEEL
17	NON RISING STEM		304SS
18	DRIVE NUT	BRONZE	BRONZE/SS
19	YOKE HUB	CARBON STEEL	STAINLESS STEEL
20	GREASE FITTING		PLATED STEEL
21	YOKE HUB BOLTS	PLATED STEEL	STAINLESS STEEL
22	WAVE SPRING		STAINLESS STEEL
23	HANDWHEEL		CAST IRON
24	RETAINER WASHER		STAINLESS STEEL