

1.0 Safety Information – Definition of Terms



WARNING

indicates a potentially hazardous situation which, if not avoided, **could** result in death or serious injury.



CAUTION

indicates a potentially hazardous situation which, if not avoided, may result in minor or moderate injury.

NOTICE

used without the safety alert symbol indicates a potential situation which, if not avoided, may result in an undesirable result or state.

1.1 Hazard-free use

This device left the factory in proper condition to be safely installed and operated in a hazard-free manner. The notes and warnings in this document must be observed by the user if this safe condition is to be maintained and hazard-free operation of the device assured.

Take all necessary precautions to prevent damage to the actuator due to rough handling, impact, or improper storage. Do not use abrasive compounds to clean the actuator, or scrape metal surfaces with any objects.

The control systems in which the actuator is installed must have proper safeguards to prevent injury to personnel, or damage to equipment, should failure of system components occur.

1.2 Qualified Personnel

A qualified person in terms of this document is one who is familiar with the installation, commissioning and operation of the device and who has appropriate qualifications, such as:

- Is trained in the operation and maintenance of pneumatic equipment and systems in accordance with established safety practices
- Is trained or authorized to energize, de-energize, ground, tag and lock electrical and pneumatic circuits and equipment in accordance with established safety practices
- Is trained in the proper use and care of personal protective equipment (PPE) in accordance with established safety practices
- Is trained in first aid
- In cases where the device is installed in a potentially explosive (hazardous) location – is trained in the operation, commissioning, operation and maintenance of equipment in hazardous locations



WARNING

The actuator must only be installed, commissioned, operated and repaired by qualified personnel. The device generates large mechanical force when pressurized with air, and/or powered by springs. The actuator stores a large amount of energy when pressurized with air, and/or when the springs are compressed.

To prevent injury, installation, commissioning, operation and maintenance must be carried out under strict observation of the safety regulations.

Reference is specifically made here to observe the applicable safety regulations for actuators installed in potentially explosive (hazardous) locations.

Correct and safe operation of this actuator is dependent upon proper transport, storage and installation in addition to proper operation and maintenance.

2.0 Description of Operation

The Bray Series 92 and 93 Pneumatic Actuators feature a double piston, rack and pinion mechanism designed to automate quarter-turn valves. In the Series 92 Double-Acting Actuator, pressure introduced through Port A (the left port when facing the ports) forces the pistons away from each other and causes the pinion to rotate in a counterclockwise direction. Pressure introduced through Port B (the right port when facing the ports) is directed through an internal passage to the opposite side of the pistons, which forces the pistons together and rotates the pinion in a clockwise direction. Normally, the clockwise rotation (pistons moving together) closes the attached valve, and the counterclockwise rotation (pistons moving apart) opens the attached valve.

In the Series 93 Spring-Return Actuators, spring cartridges have been added to push the pistons together by spring force in the event the compressed air pressure is lost. This spring force normally closes the attached valve. However, in the event that the valve is required to open under spring force, refer to the *fail open* portion of the **Installation** section below.

2.1 Operating Medium

NOTICE

The recommended operating medium is clean, dry industrial compressed air, 40 - 140 psig (3 - 10 bar.) An air line lubricator is suggested for fast cycling applications, i.e. more than 10 cycles per minute. Other media such as hydraulic oil, water, or certain other inert gases may also be used in some instances, but the factory should be consulted for specific applications.

2.2 Operating Temperature

NOTICE

The recommended operating temperature range is -15°F to 200°F (-25°C to 95°C). Below 32°F (0° C) care must be taken to prevent condensed moisture from freezing in the air supply lines. Consider the use of an air dryer if the device is installed in a cold location. The air dryer must be capable of lowering the dew point of the air to a temperature 36°F (20 °C) lower than that of the surrounding environment. The air dryer must be properly maintained and kept in operation.

3.0 Installation

Bray Series 92/93 Actuators are designed to mount directly on the top plate of Bray Valves. Before the actuator is mounted on a valve, it is a good practice to lubricate the output bore of the actuator with a thick grease. The grease will make it easier to remove the actuator from the valve stem, even after years of service.

Normally, the actuator is mounted with its long side parallel to the pipe line. A double acting actuator will normally rotate the valve stem clockwise to close, and counterclockwise to open. Spring return actuators will normally rotate the valve stem clockwise to close with the spring stroke, and counterclockwise to open with the air stroke. The normal operation of the spring cartridges is therefore *fail closed*.

Direction of operation may be changed to *fail open* by any one of several different methods. Refer to the Assembly Instructions and Exploded View in Figure 4 on page 14 for more details.

Fail Open Method 1 – Mounting the Actuator Perpendicular to the Pipeline

NOTICE

Fail Open Method 1 – Mounting the Actuator Perpendicular to the Pipeline – works only with concentric disc valves such as the Bray Series 20/21, 22/23 and 30/31 or other valves that allow the disc to be swung through the seat.

Turn the actuator so the long side is perpendicular to the pipeline. This will allow the spring cartridges to rotate the valve stem clockwise to open, and the air stroke to rotate the valve stem counterclockwise to close. This is the easiest method if there is sufficient room to mount the actuator.

Fail Open Method 2 – Rotating the Pinion

NOTICE

Fail Open Method 2 – Rotating the Pinion - works only with concentric disc valves such as the Bray Series 20/21, 22/23 and 30/31 or other valves that allow the disc to be swung through the seat.

See **Assembly** (Section 6.0) for detailed instructions on reinstalling the travel stop cam on the pinion.



WARNING

Before disassembly of the actuator, the pneumatic air supply must be completely disconnected from the actuator, and all compressed air stored within the actuator must be released. Auxiliary devices connected to the actuator, such as tubing, ball valves, solenoid air valves, valve positioners, etc. can block the release of air from within the actuator. Do not rely upon the features or controls of any auxiliary device to release the air from inside the actuator and render it safe for disassembly.



WARNING

Some actuators may have spring cartridges installed. Before disassembly, all spring cartridges must be placed into the relaxed (fully extended) position. All compressed air must be removed from inside the actuator (See warning above) and the actuator pinion must be allowed to rotate so the springs may be relaxed. Care must be taken to verify that any device connected to the actuator, such as a valve mounted underneath, is not preventing the movement of the springs to the relaxed position.

Remove the end caps, spring cartridges and pistons from the actuator. Remove the pinion, rotate it 90°, and reinstall the pinion in the actuator. This will also allow the spring cartridges to rotate the valve stem clockwise to open, and the air stroke to rotate the valve stem counter-clockwise to close. This is the second easiest method, and allows the actuator to be mounted with its long side parallel to the pipeline.

Fail Open Method 3 – Reversing the Pistons

NOTICE

Fail Open Method 3 – Reversing the Pistons – works for all valves, but must be used with offset disc valves such as the Bray Series 40/41, 42/43 and 44/45, or other offset disc valves where the disc may only turn clockwise to close.

See **Assembly** (Section 6.0) for detailed instructions on reinstalling the travel stop cam on the pinion.

Remove the end caps, spring cartridges and pistons from the actuator. Rotate the pistons so that the racks turn the pinion counterclockwise as the pistons move toward each other. (With the air input ports of the actuator body facing you, the left hand piston rack should be on the side with the air ports.) This is the third easiest method, and allows the actuator to be mounted with its long side parallel to the pipeline, and clockwise to close rotation to be maintained.

3.1 Mounting the Actuator to the Valve

The actuator is attached to the valve by means of the studs and nuts furnished in the mounting kit. Thread the studs into the proper holes in the actuator, before installing the actuator on the valve. The studs should be snug in the bottom of the tapped holes; there is no need to torque them. Install the actuator on the valve making sure that the base of the actuator fits flat against the valve mounting flange. Use the nuts and washers from the kit to complete the installation. Torque the nuts in a diagonal pattern to assure equal loading of the studs.

3.2 Setting the Travel Stops

The final step in the installation process is to check the travel stop settings. The travel stops are set for 90° of travel at the factory, however, each installation is different so they should be checked before putting the valve in service. The actuators are designed with a nominal 5° over or under travel at each end of rotation. A screwdriver, an open end or box end wrench and a hex wrench, all of the appropriate size, are the only tools required to make the necessary adjustments. Refer to Figure 1 below.



WARNING

Before setting the travel stops, the pneumatic air supply must be completely disconnected from the actuator, and all compressed air stored within the actuator must be released. Auxiliary devices connected to the actuator, such as tubing, ball valves, solenoid air valves, valve positioners, etc. can block the release of air from within the actuator. Do not rely upon the features or controls of any auxiliary device to release the air from inside the actuator and render it safe for disassembly.

Remove the black position pointer to expose the wrench flats on the top of the pinion.

Rotate the valve to the desired position using a wrench on the pinion.

Loosen the lock nut on the travel stop screw. It is not necessary to remove the nut completely. Using the hex wrench, turn the screw in or out until the desired travel stop position is reached. While holding the screw with the hex wrench, tighten the lock nut with the wrench.

Replace the position indicator making certain the pointer is aligned with the position of the valve, open or closed.

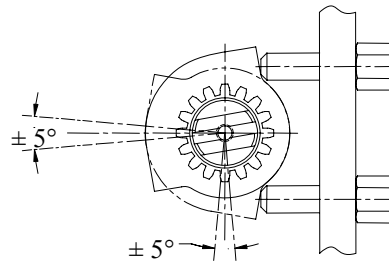

Figure 1

Some valves or operating conditions require that the actuator have more than 5° of travel adjustment. For these conditions, the Series 92/93 actuator can be fitted with extended travel stops in the end caps. (See Drawing ES11A-0460 in Figure 3 on page 6) Consult the Bray distributor in your area for this option.

Spring return actuators may be operated with only one air supply connected to Port A, since the spring cartridges will move the pistons when the air pressure is removed. This operation, however, will draw the surrounding atmosphere into the spring chambers through Port B.

NOTICE

To prevent contamination from entering the spring chamber, actuators configured to operate with only one air supply connected to Port A should be equipped with a 40 micron (or finer) filter element installed in Port B.

Even better service may be obtained on spring return actuators by installing a four-way solenoid, covering both Port A and Port B. A four-way solenoid will fill the spring chambers with compressed air from the plant air supply with each stroke. The plant air supply is often cleaner than the surrounding atmosphere, especially in heavy industrial or chemical areas.

4.0 Maintenance

The rugged components and factory lubrication combine to ensure a long and trouble-free service life for Series 92/93 actuators. Dirt, rust and water are the most common causes for shortened service life, and they typically enter the actuator through the air supply line.

NOTICE

To lengthen service life, it is strongly recommended that an adequately sized filter with a 40 micron (or fine) element be installed adjacent to the inlet of the directional control (solenoid air) valve. Air lubricators are recommended for rapid cycling applications (10 cycles or more per minute.)

Routine maintenance of Series 92/93 actuators consists primarily of maintaining the air supply system by changing filter elements before they start by-passing, adding oil to lubricators before they run dry, and preventing water from entering the air lines.

The second most common cause of shortened service life is misalignment between the valve and the actuator. This can cause premature failure due to excessive side loads on the bearings and gear teeth.

NOTICE

To lengthen service life, the mechanical connection between the actuator and the valve should be verified to be properly aligned and free to rotate throughout the full range of valve travel.

5.0 Troubleshooting

Table 1 shows several common symptoms and their remedies.

Symptom	Probable Cause	Check	Remedy
Loss of Power	Low air supply pressure, or damaged O-rings	Air supply pressure at actuator, leakage across O-rings	Boost air supply pressure, repair air supply line leaks, replace O-rings
Binding between valve and actuator	Misalignment of coupling	Alignment	Realign coupling
Valve "pops" out of seat and slams open	Valve torque too high, actuator sized too small, or insufficient air supply flow	Valve torque, actuator sizing calculations, size of air supply lines and/or solenoid valve	Repair valve, use proper size actuator, use larger air supply lines and/or solenoid valve with higher flow

6.0 Assembly

To identify component names and shapes, refer to the Exploded View of the actuator shown in Figure 4. The numbers in parentheses () refer to the numbered bubbles in Figure 4. Easiest assembly will result from lubricating all bearings and seals as they are installed. The lubricant should be a high pressure or extreme pressure petroleum grease with a lithium based thickener which meets the NLGI¹ grade 2. Grease which meets this specification should be available from any automotive supply store.

¹ National Lubricating Grease Institute

Pinion (3) - Install bearing rings (6 & 7) and o-rings (18 & 19) in their appropriate grooves. Insert the pinion through the large hole in the center of the body (1). With the pinion part of the way into the body, slide the cam (23) over the pinion being careful to align the punch mark on the cam with the punch mark(s) on the pinion. For normal installation and rotation (*Fail Close*), align the single marks. For *Fail Open* operation described in *Method 2* above, align the single mark on the cam with the two marks on the pinion. For *Fail Open* operation described in *Method 3* above, align the single marks. Next, install the spacer (24) above the cam. Then insert the pinion through the hole at the top of the body and secure it with the washer (9) and retaining ring (8).

Travel Stop Screws (13) - Slip the o-ring (14) over the flat end of the screw until it is 5-7 threads from the end. Thread the screw into the hole in the body, flat end first. Repeat these steps for the second screw. Thread the lock nuts (12) onto the screws and tighten the nuts against the body. This will seal the threads for testing. It is not necessary to set the travel stops at this time as they may have to be re-set when the actuator is installed on the valve.

Pistons (2) - Install the bearing pad (10) on the back of the rack and the o-ring (16) and guide ring (11) in their appropriate piston grooves. The o-ring goes in the groove nearest the rack. With the ports on the actuator body toward you, turn the pinion so that the slot is approximately 45° to the right of perpendicular with the long side of the body. Grasp the pistons in the spring pockets so that the piston in the right hand has the bearing pad toward you and the piston in the left hand has the bearing pad away from you. Slide the pistons into the body so that they both engage the teeth on the pinion at the same time. Apply enough steady force to compress the o-ring into the body bore. At this point, you may continue pushing or use a wrench on the top of the pinion to pull the pistons into the body.

NOTICE

Three important parameters must be verified before assembly may be continued.

- 1) The pinion must turn clockwise as the pistons moved toward the center of the body.
- 2) The 4 mm slot in the top of the pinion must be within a few degrees of perpendicular to the long side of the body.
- 3) The piston faces must both be the same distance from the end of the body.

If all three parameters above have been verified, the end caps may be installed.

If any parameter above is not verified, use a wrench on the pinion to drive the pistons out of the body and repeat the insertion process. It is not necessary to remove the pistons from the body unless the answer to the first question is no. It is only necessary to disengage the piston rack from the pinion.

NOTICE

The assembly procedure described here is the standard Fail Close method. For Fail Open actuators, refer to *Method 2* or *Method 3* above.

End Caps(4) - Install the o-ring (17) in the groove. Attach the end cap to the body with the 4 bolts (15) and washers (20) making certain that the straight part of the o-ring groove is toward the bottom of the body. The air pressure will not flow to the outboard side of the pistons if the straight part of the o-ring groove is at the top.

Position Indicator (21) - Install the position indicator pointer on the top of the pinion and secure it with the flat head screw (22). Normally, the long axis of the pointer will be parallel to the groove in the pinion. If the actuator is installed across the pipe line, as described in Method 1 above, the indicator should be turned so that it is in line with the butterfly valve disc or port in the ball or plug valve.

7.0 Final Assembly and Testing



CAUTION

Do not connect a compressed air supply to the actuator that exceeds the pressure rating of the actuator (140 psig / 10 barg.)

Connect the compressed air supply to the actuator input ports and cycle the actuator fully open and fully closed to check for proper travel and absence of air leaks. Air supply lines should have a minimum inside diameter of 0.250" (6 mm). Restricted air supply lines, or any portion of the air supply system powering the actuator (such as solenoid air valves or valve manifolds) can reduce actuation time, cause unexpected popping of the valve, or even malfunction.

If compressed air is applied to Port A and the actuator reaches the end of travel, there should be no air flow out of Port B, and vice versa. There should be no air flow between the end caps and the body, through the travel stops, or out the top or the bottom of the pinion. A solution of soap and water applied to the sealing points can indicate leaks that are too small to be audible.

8.0 Disassembly



WARNING

Before disassembly of the actuator, the pneumatic air supply must be completely disconnected from the actuator, and all compressed air stored within the actuator must be released. Auxiliary devices connected to the actuator, such as tubing, ball valves, solenoid air valves, valve positioners, etc. can block the release of air from within the actuator. Do not rely upon the features or controls of any auxiliary device to release the air from inside the actuator and render it safe for disassembly.



WARNING

Some actuators may have spring cartridges installed. Before disassembly, all spring cartridges must be placed into the relaxed (fully extended) position. All compressed air must be removed from inside the actuator (See warning above) and the actuator pinion must be allowed to rotate so the springs may be relaxed. Care must be taken to verify that any device connected to the actuator, such as a valve mounted underneath, is not preventing the movement of the springs to the relaxed position.

If the actuator is installed on a valve, remove the actuator from the valve, and move the actuator to a clean work area. Remove the indicator pointer. Remove both end caps by loosening the hex head end cap bolts. Remove both pistons by rotating the pinion counterclockwise until the piston heads are protruding from the body. Pull the pistons out. Using snap-ring pliers, remove the pinion retaining ring and acetal washer, then remove the pinion from the body. The pinion bearings, o-rings, cam and spacer may then be removed.

9.0 Adding Spring Cartridges



WARNING

Before disassembly of the actuator, the pneumatic air supply must be completely disconnected from the actuator, and all compressed air stored within the actuator must be released. Auxiliary devices connected to the actuator, such as tubing, ball valves, solenoid air valves, valve positioners, etc. can block the release of air from within the actuator. Do not rely upon the features or controls of any auxiliary device to release the air from inside the actuator and render it safe for disassembly.

Move the pinion to the fully closed (0°) position. Remove the end caps and insert the desired number of spring cartridges into the end cap pockets, up to a maximum of six cartridges per end cap.

NOTICE

For proper operation, actuators equipped with Spring Cartridges should have the spring cartridges installed in accordance with the positions shown in Figure 2 below.

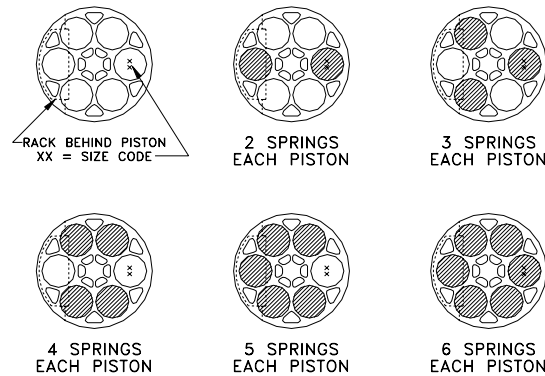

Figure 2

Align the end cap with the body so the spring cartridges fit into the piston pockets. Attach the end caps to the body with the hex head end cap bolts. Tighten the bolts gradually in a diagonal sequence. Proceed to Final Assembly and Testing.

9.1 Removing Spring Cartridges



WARNING

Before disassembly of the actuator, the pneumatic air supply must be completely disconnected from the actuator, and all compressed air stored within the actuator must be released. Auxiliary devices connected to the actuator, such as tubing, ball valves, solenoid air valves, valve positioners, etc. can block the release of air from within the actuator. Do not rely upon the features or controls of any auxiliary device to release the air from inside the actuator and render it safe for disassembly.



CAUTION

Before disassembly, all spring cartridges must be placed into the relaxed (fully extended) position. All compressed air must be removed from inside the actuator (See warning above) and the actuator pinion must be allowed to rotate so the springs may be relaxed. Care must be taken to verify that any device connected to the actuator, such as a valve mounted underneath, is not preventing the movement of the springs to the relaxed position.

An actuator with spring cartridges installed and no compressed air connected will move to the spring fail position if the pinion is free to rotate. This may be either fully closed (0°) or fully open (90°). In either case, when the spring fail position is reached, remove the end caps by gradually loosening the hex head end cap bolts in a diagonal sequence.



CAUTION

When removing end caps from an actuator containing spring cartridges, the end cap bolts must be loosened gradually in a diagonal sequence until the spring cartridges are completely relaxed (fully extended.) The spring cartridges should reach the completely relaxed (fully extended) position while all four end cap bolts still have some thread engagement with the actuator body. Do not remove three end cap bolts completely from the body and expect the remaining single bolt to hold the spring cartridges in a compressed position.

Remove the spring cartridges. Replace the end caps and tighten the end cap bolts gradually in a diagonal sequence.



CAUTION

When replacing end caps onto an actuator containing spring cartridges, the end cap bolts must be tightened gradually in a diagonal sequence until the spring cartridges are slightly compressed into their fail position. The spring cartridges should reach the slightly compressed fail position while all four end cap bolts have some thread engagement with the actuator body. Do not attempt to tighten a single end cap bolt fully and compress the spring cartridges while the other three bolts have not been installed.

Proceed to Final Assembly and Testing.

10.0 General Pneumatic System Recommendations

To maintain maximum efficiency with the Series 92/93 actuator, as well as many other pneumatic devices, the following suggestions are offered:

- ⊙ Air supply lines should be run in accordance with a Standard Piping Practice, and should not have exaggerated loops which may trap condensate.
- ⊙ All pipe ends should be thoroughly cleaned and deburred after cutting to ensure that the pipeline is clear of cuttings.
- ⊙ Where air pipelines are subjected to extremes of temperature, the system should be fitted with air drying equipment.
- ⊙ If pipelines are hydraulically tested, the lines should be "blown down" with high pressure air to clear all water prior to connecting the lines to the actuator.
- ⊙ Where a system is dependent on air filter equipment, the air filters should be in positions that allow easy access for maintenance and/or draining.
- ⊙ Where pneumatic valve positioners or pneumatic controllers are installed in a valve actuator assembly, oil mist lubricated air should not be used unless the manufacturer states specifically that the positioner or controller is compatible with lubricated air. In general, lubricated air is not recommended for a positioner.

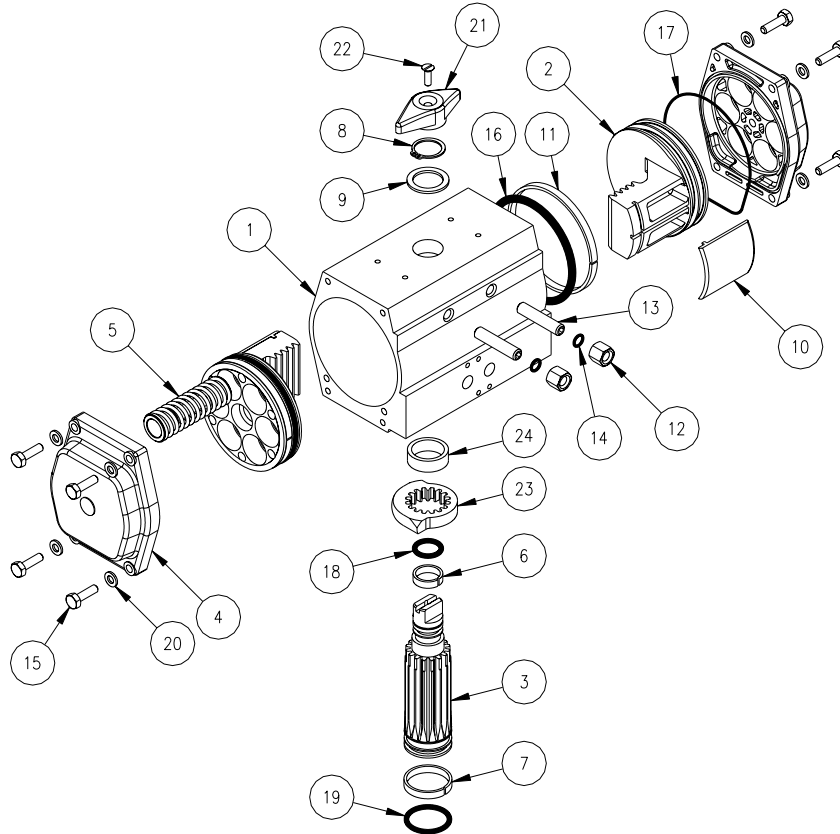

Figure 4
 Series 92/93 Exploded-view

Item No	Qty.	Description
1	1	Body
2	2	Piston
3	1	Pinion
4	2	End Cap
5	12 max.	Spring Cartridge
6	1	Upper Pinion Bearing
7	1	Lower Pinion Bearing
8	1	Retaining Ring
9	1	Washer, Acetal
10	2	Bearing Pad, Acetal
11	2	Guide Ring, Acetal
12	2	Lock Nut

Item No	Qty.	Description
13	2	Travel Stop Screw
14	2	O-ring, Travel Stop
15	8	Hex Head Cap Screw
16	2	O-ring, Piston
17	2	O-ring, End Cap
18	1	O-ring, Upper Pinion
19	1	O-ring, Lower Pinion
20	8	Washer, Stainless Steel
21	1	Position Indicator Pointer
22	1	Flat Head Screw
23	1	Cam, Internal Travel Stop
24	1	Spacer, Int. Travel Stop