

# Flow-Tek®

A Subsidiary of BRAY INTERNATIONAL, Inc.

## 1 Piece Flanged Standard Port Ball Valves: 1" - 12" ASME Class 150 & Class 300



Flow-Tek's Series RF15 & RF30 ball valves feature a compact, one piece body design with threaded insert. The one piece body supplies maximum structural strength while minimizing the number of potential leak paths. A floating ball design offers low torque and increases valve cycle life. These rugged, economical, end entry flanged ball valves are ideal for industrial applications.

**Non-Fire Safe and API 607 4th Edition Fire Safe Valves** Series RF15/RF30 valves are available as non-fire safe with standard stem seals or fire safe to API 607 4th Edition with graphite stem seals.

**Secure Mount** Series RF15/RF30 valves offer ease of automation due to an integrally cast actuator mounting pad that complies with ISO 5211 through 2" valve sizes.

### Pressure Ratings

Model RF15: ASME Class 150  
Model RF30: ASME Class 300

### Body Materials

Stainless Steel  
Carbon Steel  
Special Alloys upon request



**Stem Seals** Series RF15/RF30 1"– 2" valves feature live-loaded, self-adjusting primary and secondary sealing. Utilizing Belleville washers, the stem seal automatically adjusts to compensate for changes in temperature and normal wear. 3"– 12" valves utilize an independent packing gland which can be easily adjusted without removing mounting hardware or operator. The packing gland is contoured to more uniformly distribute the load across the packing.

The primary seal is a combination of a thrust washer and thrust washer protector. An adjustable stem packing creates a secondary seal between the stem and body. The stem packing is composed of RPTFE V-rings as standard – graphite stem packing is standard on all Fire Safe valves.

**Ball** Flow-Tek balls are precision machined and mirror finished for bubble-tight shut off and less operating torque. As an added safety feature, a hole in the stem slot of each ball equalizes pressure between the body cavity and the line media flow.

**Body** 1"–4" valve bodies are investment cast and all valve size castings are solution annealed/normalized for the highest quality and added strength. All body castings are marked with a foundry heat number for full traceability.

**Seat** Flow-Tek's seat design ensures bi-directional, bubble-tight sealing with low operating torque. All resilient seats feature relief slots or seat O.D. clearance to relieve pressure past the upstream seat and provide positive preloading to ensure low pressure/vacuum sealing.

**Anti-Static Devices** All RF15/RF30 valves have Anti-Static Devices as standard. These devices positively ground ball and stem.

---

## Seat Selection

A wide range of seat materials are available to meet most applications. The standard seat is TFM 1600. Optional seats include RPTFE, Stainless Steel/PTFE (50/50), UHMWPE, Virgin PTFE, PEEK, Tek-Fil® (carbon/graphite filled TFM), and full metal seats and Cavity Fillers. PEEK seats offer high pressure/temperature capability. Tek-Fil seats offer reduced torque in high temperature, high cycle, and steam service applications. TFM1600 seats offer the exceptional chemical resistance of PTFE plus lower porosity and permeability, improved temperature range and reduced valve torques.

---

## Options

Flow-Tek Series RF15/RF30 valves are available as V-Control valves. For more information please see Flow-Tek VC brochure and Technical Bulletin 1006. A safety exhaust is available for downstream venting. Tri-Port balls for self draining and additional options are available upon request. For more information please consult the Flow-Tek factory.

---

## Features

### Fire Safe: API 607-4 Certified

Flow-Tek's Series RF15/RF30 valves with graphite stem packing meet the highest fire safety standards under extreme conditions. In the event of a fire, after heat destroys the primary resilient seat, the ball makes contact with the secondary metal seat, forming a secure seal.

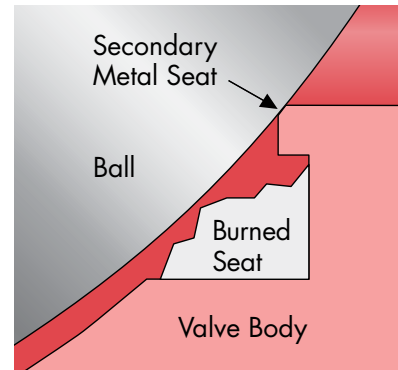

Flow-Tek offers a **Media Containment Unit** as an option. This unit easily mounts to standard valves through 10" and adds an additional stem packing seal for difficult services.



All manually operated valves feature a **Locking Device** to prevent accidental movement of ball position. 1"– 2" valves feature a Safety Trigger that locks the handle in the open or closed position. The handle lock can be bypassed, if needed, with a small bolt through the handle in the release position. On all sizes a **Padlock** can be added to secure the handle in position, preventing unwanted movement of the ball.

3" through 6" valves feature a NAMUR stem slot for ease of limit switch mounting.

# Technical Data

## Components & Materials

For Valve Sizes 1" through 12"

Carbon Steel bodies on Valve sizes 1" – 2" are Black Phosphate Coated.

All Stainless Steel bodies are solution annealed/normalized.

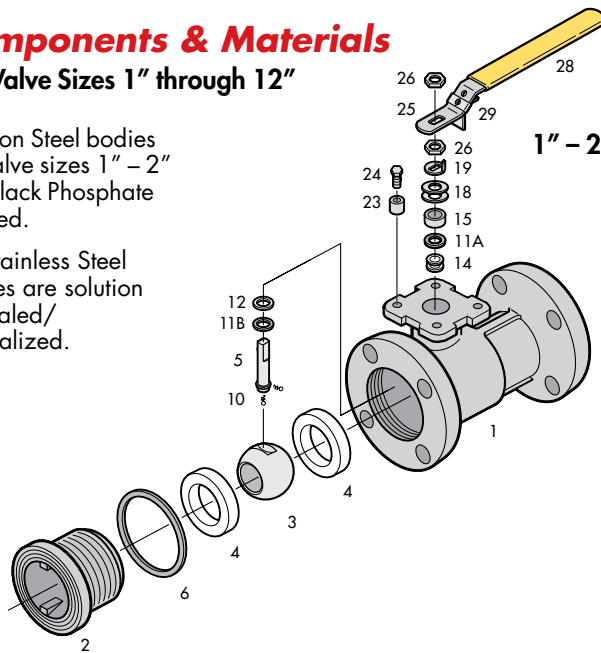

1" – 2" Valves

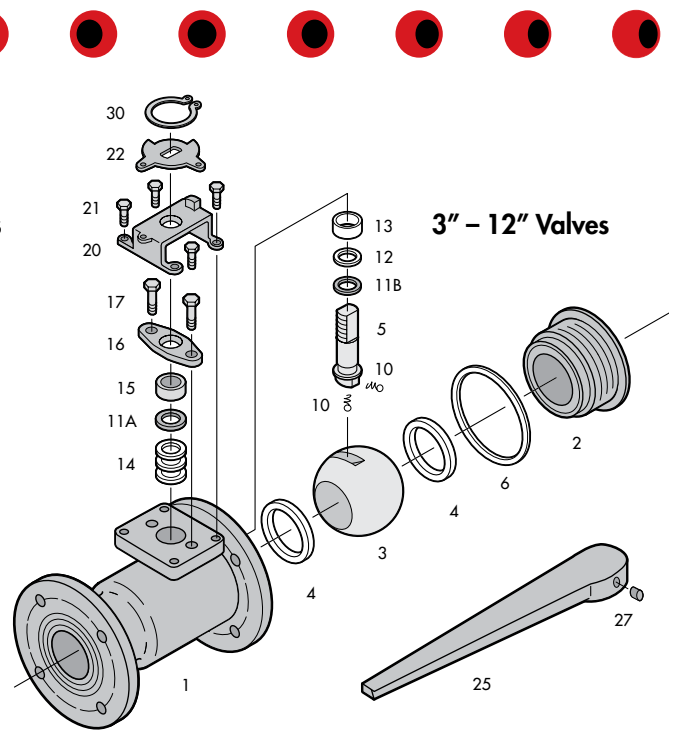

3" – 12" Valves

## Specifications

Flanged End Connections meet ASME Class 150/300.

Flanges meet ASME B16.5.

Face to Face Dimensions meet ASME B16.10 short pattern.

All valves meet ASME B16.34, MSS-SP-72 and API 608.

Fire Safe Valves with graphite Stem Packing are certified to API 607 4th Edition.

NACE MR0175 - All internal wetted parts.

All Valves are Hydrostatically Pressure Tested (Shell) and Air Pressure Tested (Seat) to the following in psi:  
 Class 150: Shell 450 [CS] 425 [SS] Seat 80  
 Class 300: Shell 1125 [CS] 1100 [SS] Seat 80

## Pressure / Temperature

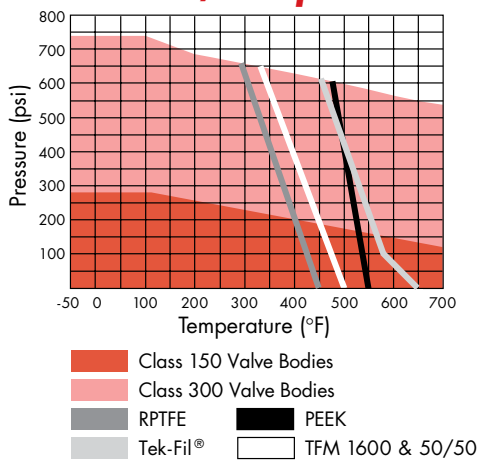

Note: Carbon Steel valves limited to -20°F.

### Steam Service Pressure Ratings: WSP

Valve	TFM Seats		Tek-Fil Seats		PEEK Seats	
	PSI	°F	PSI	°F	PSI	°F
Class 150	150	365	200	450	200	500
Class 300	150	365	425	450	425	500

Vacuum Service to 29 inches Hg. gauge.

Item	Name	Stainless Steel	Carbon Steel	Qty.
1	Body	ASTM A351 Gr CF8M	ASTM A216 Gr WCB	1
2	End Cap	ASTM A351 Gr CF8M	ASTM A216 Gr WCB	1
3	Ball	ASTM A351 Gr CF8M	ASTM A351 Gr CF8M	1
4	Seat*	TFM 1600	TFM 1600	2
5	Stem	ASTM A479 Gr 316	ASTM A479 Gr 316	1
6	Body Seal*	RPTFE	RPTFE	1
10	Anti-Static Device	SS316	SS316	2
11A	Packing Protector*	PEEK	PEEK	1
11B	Thrust Washer Protector*	PEEK	PEEK	1
12	Thrust Washer*	50% SS316 + 50% PTFE	50% SS316 + 50% PTFE	1
13	Stem Bearing*	15% RPTFE	15% RPTFE	1
14	Stem Packing*	RPTFE/Graphite	RPTFE/Graphite	3/1
15	Packing Gland Sleeve	SS304	Carbon Steel <sup>1</sup>	1
16	Packing Gland Plate	ASTM A351 Gr CF8	ASTM A216 Gr WCB	1
17	Gland Bolt	SS304	Carbon Steel	2
18	Belleville Washer	SS301	SS301	2
19	Tab Washer	SS304	SS304	1
20	Travel Stop Housing	ASTM A351 Gr CF8M	ASTM A216 Gr WCB	1
21	Housing Bolt	SS304	Carbon Steel	4
22	Travel Stop	SS304	Zinc Plated Carbon Steel	1
23	Travel Stop Set Sleeve	SS304	SS304	1
24	Travel Stop Bolt	SS304	SS304	1
25	Handle	Ductile Iron <sup>2</sup>	Ductile Iron <sup>2</sup>	1
26	Lock Nut	SS304	SS304	2
27	Handle Bolt	Carbon Steel	Carbon Steel	1
28	Handle Sleeve	Vinyl	Vinyl	1
29	Locking Device	SS304	SS304	1
30	Snap Ring	Nickel Plated Carbon Steel	Nickel Plated Carbon Steel	2

\* Parts included in the repair kits.

<sup>1</sup> For 1"–2" RF15/RF30, this material is SS304.

<sup>2</sup> For 1"–2" RF15/RF30, this material is SS304.

## MODEL RF15 – Class 150

SIZE ins	A	øB	C	C1	D	E	øF	N	øS	øT	Cv	TORQUE * lbs-in	WEIGHT lbs.
1	5.00	0.79	2.91	1.67	6.50	2.00	4.25	4	3.12	0.63	32	65	6
1 1/2	6.50	1.26	3.62	2.20	7.87	2.17	5.00	4	3.88	0.63	82	155	11
2	7.00	1.50	4.20	2.61	10.43	2.56	6.00	4	4.75	0.75	120	230	18
3	8.00	2.56	5.98	3.09	15.35	3.27	7.50	4	6.00	0.75	350	390	39
4	9.00	3.00	6.53	3.66	15.35	3.86	9.00	8	7.50	0.75	720	650	54
6	10.50	4.00	7.20	4.33	38.98	4.61	11.00	8	9.50	0.87	1,020	1,505	90
8	11.50	6.00	10.83	6.85	38.98	5.85	13.50	8	11.75	0.87	1,880	3,225	170
10	13.00	7.87	11.61	7.62	38.98	6.85	16.00	12	14.25	1.00	4,000	4,750	350
12	14.00	9.53	12.76	8.92	38.98	7.00	19.00	12	17.00	1.00	7,700	13,700	550

Face to Face dimensions meet ASME B16.10 short pattern.

\*Torque at maximum rated pressure, clean water, TFM 1600 seating material. Other seat materials exhibit different torques. Please refer to TB 1005 for specific torques.

## MODEL RF30 – Class 300

SIZE ins	A	øB	C	C1	D	E	øF	N	øS	øT	Cv	TORQUE * lbs-in	WEIGHT lbs.
1	6.50	0.79	2.98	1.67	6.34	2.18	4.88	4	3.50	0.75	32	70	8.5
1 1/2	7.48	1.25	3.65	2.20	7.72	2.60	6.14	4	4.51	0.87	82	175	17
2	8.50	1.50	4.17	2.61	9.69	2.92	6.50	8	5.00	0.75	120	270	24
3	11.14	2.50	5.98	3.00	15.35	3.75	8.28	8	5.00	0.87	350	600	55
4	12.00	3.00	6.53	3.66	15.35	3.86	10.00	8	6.18	0.87	720	850	74
6	15.88	4.00	7.21	4.33	15.35	4.61	12.52	12	8.50	0.87	1,020	2,600	132
8	16.50	6.00	11.22	6.85	38.98	5.85	15.00	12	13.00	1.00	1,880	5,300	300
10	18.00	8.00	12.72	7.62	38.98	6.85	17.50	16	15.25	1.13	4,000	7,600	460
12	19.75	9.53	13.70	8.92	38.98	7.00	20.50	16	17.75	1.25	7,700	17,800	800

## SECURE MOUNT

SIZE ins	H	J	F0	BC DIA.	K	L	M	øP	U UNC
1	1.17	1.17	F04	1.65	0.31	0.55	0.25	0.37	#10-24
1 1/2	1.39	1.39	F05	1.97	0.43	0.75	0.31	0.43	1/4-20
2	1.95	1.95	F07	2.76	0.55	0.91	0.37	0.62	5/16-18
3-4 <sup>1</sup>	3.54	1.87	—	—	1.75	2.97 <sup>1</sup>	0.67	1.10	1/2-13
6	3.54	1.87	—	—	1.75	3.07	0.67	1.71	1/2-13
8	3.37	3.37	—	4.77	1.61	3.42	1.02	1.71	1/2-13
10	3.37	3.37	—	4.77	2.13	3.86	1.02	1.71	1/2-13
12	4.53	4.53	—	6.40	2.16	3.74	1.38	1.97	5/8-11

<sup>1</sup> For 4": L=3.07

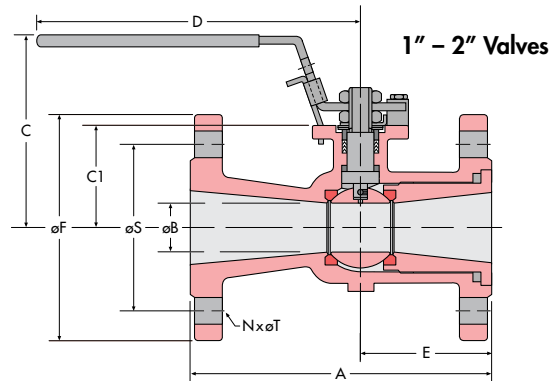

**1" – 2" Valves**

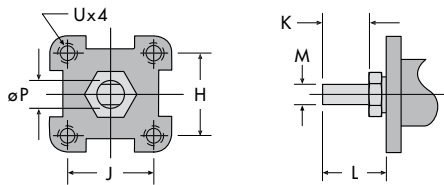

**3" – 12" Valves**

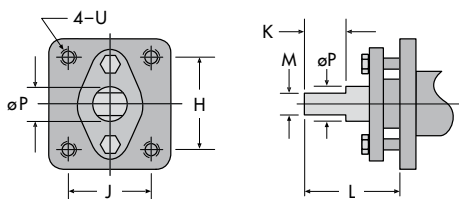

**3"–12" Valves**

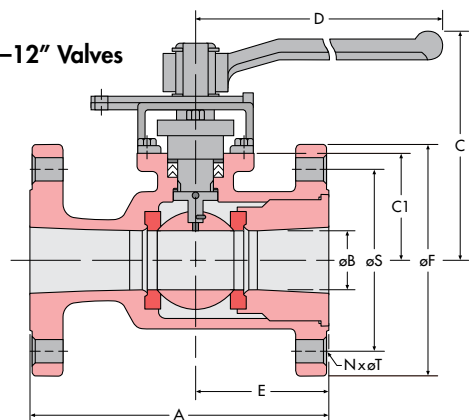

**NOTE:** Gear Operators are suggested on size 10" and 12" valves.

**NOTE:** A trunnion-like Ball Support is included on size 12" valves.

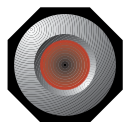

# Flow-Tek®

A Subsidiary of BRAY INTERNATIONAL, Inc.  
 11850 Tanner Road Houston, Texas 77041  
 832.912.2300 Fax: 832.912.2301  
 www.flow-tek.com

All statements, technical information, and recommendations in this bulletin are for general use only. Consult Flow-Tek representatives or factory for the specific requirements and material selection for your intended application. The right to change or modify product design or product without prior notice is reserved.

Flow-Tek® is a registered trademark of Flow-Tek, Inc.  
 © 2007 Flow-Tek, Inc. RF15/30